

REV	LOCATIONS	DESCRIPTION	DATE	REVISER	APPD

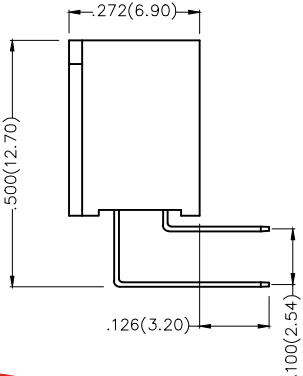

Electrical
 Current Rating: 3A AC(rms)/DC
 Voltage Rating: 250V AC(rms)/DC
 Contact Resistance: 20 mΩ Max
 Insulation Resistance: 1000 MΩ MIN
 Withstanding Voltage: 500V AC r.m.s
 Temperature Range-Operating: -40°C~+105°C

Material and Plating
 Housing: PBT/PA6T(UL 94V-0)
 Contact Pin: Phosphor Bronze
 Plating: Gold Plated/Selective gold in contact area, matte(bright) tin on tail

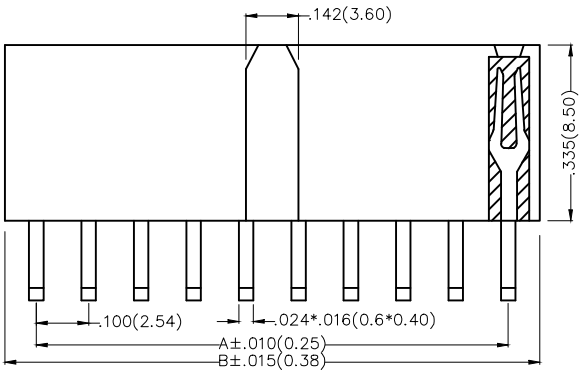
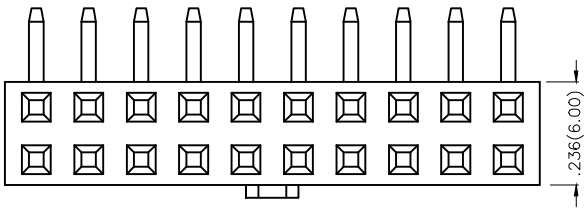

Ordering Information

FFH 254 13 — D XX B X XX X K6 K
 1 2 3 4 5 6 7 8 9 10 11

1 Category FFH-Female Header	2 Series Number 254-Pitch2.54mm	3 Distinction No. 13	4 Row Option D-Double Row	5 Circuits XX	6 Entry Angle B-90° Angle
7 Plating 1-Gold Plated 3-Selective gold in contact area, matte(bright) tin on tail	8 Thickness of Plating 00-Gold Flash 05-5μ" Custom plate available	9 Material-Resin 1-PBT 4-PA6T	10 Color-Resin K6-Black	11 Packaging K-Tray	

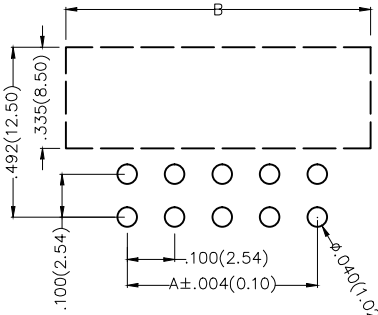

Recommended P.C.Board Layout

THIRD ANGLE PROJECTION	GENERAL TOLERANCES (UNLESS SPECIFIED)		APPROVE BY FRANK	DATE 12/AUG/13	PART NO. FFH25413-DXXBXXXXXK6K	ITEM NO. FFH25413	 3K-KAMING®
	DESIGN UNITS Inch (metric)	X.X±.012(0.30) X'±5"	CHECKED BY CHERRY	DATE 12/AUG/13	TITLE Board to Board (Female Header) Pitch 2.54mm 90° Angle (DIP)		
SCALE 5:1	SIZE A4	X.XX±.006(0.15) .XX'±1"	DRAWN BY JACOB	DATE 12/AUG/13	THIS DRAWING CONTAINS INFORMATION THAT IS PROPRIETARY TO DONG GUAN LANG LUN(3K-KAMING) ELECTRONIC PRODUCTS CO.,LTD. AND SHOULD NOT BE USED WITHOUT WRITTEN PERMISSION		

REV	LOCATIONS	DESCRIPTION	DATE	REVISER	APPD



Circuits (n)	Part No.	Dimensions(in/mm)		Circuits (n)	Part No.	Dimensions(in/mm)	
		A	B			A	B
4	FFH25413-D04BXXXXK6K	.100(2.54)	.220(5.58)	44	FFH25413-D44BXXXXK6K	2.100(53.34)	2.220(56.38)
6	FFH25413-D06BXXXXK6K	.200(5.08)	.320(8.12)	46	FFH25413-D46BXXXXK6K	2.200(55.88)	2.320(58.92)
8	FFH25413-D08BXXXXK6K	.300(7.62)	.420(10.66)	48	FFH25413-D48BXXXXK6K	2.300(58.42)	2.420(61.46)
10	FFH25413-D10BXXXXK6K	.400(10.16)	.520(13.20)	50	FFH25413-D50BXXXXK6K	2.400(60.96)	2.520(64.00)
12	FFH25413-D12BXXXXK6K	.500(12.70)	.620(15.74)	52	FFH25413-D52BXXXXK6K	2.500(63.50)	2.620(66.54)
14	FFH25413-D14BXXXXK6K	.600(15.24)	.720(18.28)	54	FFH25413-D54BXXXXK6K	2.600(66.04)	2.720(69.08)
16	FFH25413-D16BXXXXK6K	.700(17.78)	.820(20.82)	56	FFH25413-D56BXXXXK6K	2.700(68.58)	2.820(71.62)
18	FFH25413-D18BXXXXK6K	.800(20.32)	.920(23.36)	58	FFH25413-D58BXXXXK6K	2.800(71.12)	2.920(74.16)
20	FFH25413-D20BXXXXK6K	.900(22.86)	1.020(25.90)	60	FFH25413-D60BXXXXK6K	2.900(73.66)	3.020(76.70)
22	FFH25413-D22BXXXXK6K	1.000(25.40)	1.120(28.44)	62	FFH25413-D62BXXXXK6K	3.000(76.20)	3.120(79.24)
24	FFH25413-D24BXXXXK6K	1.100(27.94)	1.220(30.98)	64	FFH25413-D64BXXXXK6K	3.100(78.74)	3.220(81.78)
26	FFH25413-D26BXXXXK6K	1.200(30.48)	1.320(33.52)	66	FFH25413-D66BXXXXK6K	3.200(81.28)	3.320(84.32)
28	FFH25413-D28BXXXXK6K	1.300(33.02)	1.420(36.06)	68	FFH25413-D68BXXXXK6K	3.300(83.82)	3.420(86.86)
30	FFH25413-D30BXXXXK6K	1.400(35.56)	1.520(38.60)	70	FFH25413-D70BXXXXK6K	3.400(86.36)	3.520(89.40)
32	FFH25413-D32BXXXXK6K	1.500(38.10)	1.620(41.14)	72	FFH25413-D72BXXXXK6K	3.500(88.90)	3.620(91.94)
34	FFH25413-D34BXXXXK6K	1.600(40.64)	1.720(43.68)	74	FFH25413-D74BXXXXK6K	3.600(91.44)	3.720(94.48)
36	FFH25413-D36BXXXXK6K	1.700(43.18)	1.820(46.22)	76	FFH25413-D76BXXXXK6K	3.700(93.98)	3.820(97.02)
38	FFH25413-D38BXXXXK6K	1.800(45.72)	1.920(48.76)	78	FFH25413-D78BXXXXK6K	3.800(96.52)	3.920(99.56)
40	FFH25413-D40BXXXXK6K	1.900(48.26)	2.020(51.30)	80	FFH25413-D80BXXXXK6K	3.900(99.06)	4.020(102.10)
42	FFH25413-D42BXXXXK6K	2.000(50.80)	2.120(53.84)				



 THIRD ANGLE PROJECTION	GENERAL TOLERANCES (UNLESS SPECIFIED)		APPROVE BY	DATE	PART NO.	ITEM NO.	 3K-KAMING
	X.±0.12(0.30)	X.±5'	FRANK	12/AUG/13	FFH25413-DXXBXXXXK6K	FFH25413	
DESIGN UNITS Inch (metric)	X.X±.008(0.20)	.X'±2'	CHECKED BY	DATE	TITLE		REV 0 SHEET NO. 1/1
SCALE SIZE	X.XX±.006(0.15)	.XX'±1'	CHERRY	12/AUG/13	Board to Board (Female Header) Pitch 2.54mm 90° Angle (DIP)		
5:1 A4	X.XXX±.004(0.10)	.XXX'±0.5'	DRAWN BY	DATE	THIS DRAWING CONTAINS INFORMATION THAT IS PROPRIETARY TO DONG GUAN LANG LUN(3K-KAMING) ELECTRONIC PRODUCTS CO.,LTD. AND SHOULD NOT BE USED WITHOUT WRITTEN PERMISSION		
			JACOB	12/AUG/13			