

Dimensions(in/mm)		
H	W	K
.039(1.00)	.134(3.40)	.059(1.50)
.059(1.50)		
.079(2.00)	.118(3.00)	.039(1.00)
.098(2.50)		

REV	LOCATIONS	DESCRIPTION	DATE	REVISER	APPD



SPECIFICATIONS

Electrical
 Current Rating: 1.0A AC(rms)/DC
 Voltage Rating: 250V AC(rms)/DC
 Contact Resistance: 20 mΩ Max
 Insulation Resistance: 1000 MΩ Min
 Withstanding Voltage: 600V AC r.m.s
 Temperature Range—Operating: -40°C~+105°C

Material and Plating
 Housing: Glass Filled Polyester (UL 94V-0), Color: Black
 Pin: Brass
 Pin Plating: Gold plated/ Selective gold plated on contact area and 120μ" Min. matte tin plated on tails area

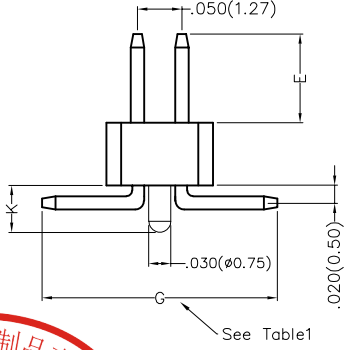
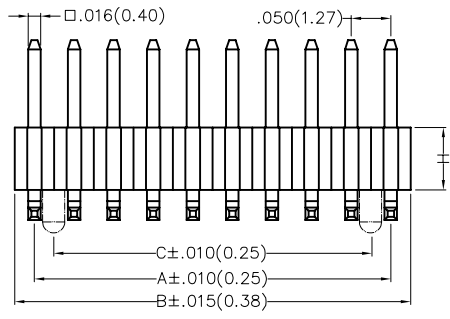
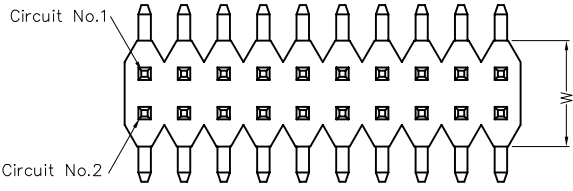

Ordering Information

FPH 127 47 - D XX S X XX X XX XX X 0 M
 1 2 3 4 5 6 7 8 9 10 11 12 13

1 Category FPH-Pin Header	2 Series Number 127-Pitch1.27mm	3 Distinction No. 47	4 Row Option D-Double Row	5 Circuits XX	6 Entry Angle S-180° Vertical	7 Plating 1-Gold plated 7-Selective gold plated on contact area and matte tin plated on tails area
8 Thickness of Plating 01-1μ" 15-15μ" Custom plate available	9 Material-Resin 3-LCP 4-PA6T 5-PA9T	10 E Size 01,02...-Serial number (See Table1)	11 G Size 01,02...-Serial number (See Table1)	12 H Size 1,2...-Serial number (See Table1)	13 Packaging M-Reel	

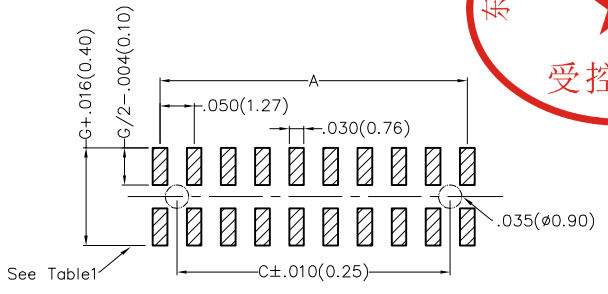

Recommended P.C.Board Layout

THIRD ANGLE PROJECTION	GENERAL TOLERANCES (UNLESS SPECIFIED)		APPROVE BY FRANK	DATE 17/DEC/19	PART NO. FPH12747-DXXXSXXXXXXXXXOM	ITEM NO. FPH12747			
	X.±.012(0.30)	X.±5'	CHECKED BY CHERRY	DATE 17/DEC/19	TITLE Board to Board(Pin Header) Pitch 1.27mm 180° Vertical(SMT)			REV 0	SHEET NO. 1/3
	X.XX±.008(0.20)	.X'±2'	DRAWN BY ZOEY	DATE 17/DEC/19	THIS DRAWING CONTAINS INFORMATION THAT IS PROPRIETARY TO DONG GUAN LANG LUN(3K-KAMING) ELECTRONIC PRODUCTS CO., LTD. AND SHOULD NOT BE USED WITHOUT WRITTEN PERMISSION				
SCALE 5:1	SIZE A<	X.XX±.006(0.15)	.XX'±1'	X.XXX±.004(0.10)	.XXX'±0.5'				

REV	LOCATIONS	DESCRIPTION	DATE	REVISER	APPD

Table1

Serial number	Dimensions(in/mm)		Serial number	Dimensions(in/mm)	
	E			E	
01	.059(1.50)		19	.236(6.00)	
02	.069(1.75)		20	.246(6.25)	
03	.079(2.00)		21	.256(6.50)	
04	.089(2.25)		22	.266(6.75)	
05	.098(2.50)		23	.276(7.00)	
06	.108(2.75)		24	.285(7.25)	
07	.118(3.00)		25	.295(7.50)	
08	.128(3.25)		26	.305(7.75)	
09	.138(3.50)		27	.315(8.00)	
10	.148(3.75)		28	.325(8.25)	
11	.157(4.00)		29	.335(8.50)	
12	.167(4.25)		30	.344(8.75)	
13	.177(4.50)		31	.354(9.00)	
14	.187(4.75)		32	.364(9.25)	
15	.197(5.00)		33	.374(9.50)	
16	.207(5.25)		34	.384(9.75)	
17	.217(5.50)		35	.394(10.00)	
18	.226(5.75)				

Serial number	Dimensions(in/mm)	
	G	
01	.157(4.00)	
02	.167(4.25)	
03	.177(4.50)	
04	.187(4.75)	
05	.197(5.00)	
06	.207(5.25)	
07	.217(5.50)	
08	.226(5.75)	
09	.236(6.00)	
10	.246(6.25)	
11	.256(6.50)	
12	.266(6.75)	
13	.276(7.00)	
14	.285(7.25)	
15	.295(7.50)	
16	.305(7.75)	
17	.315(8.00)	

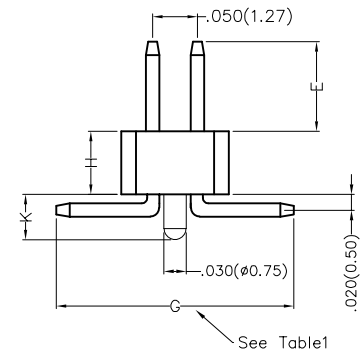

Serial number	Dimensions(in/mm)
H	
1	.039(1.00)
2	.059(1.50)
3	.079(2.00)
4	.098(2.50)



<p>THIRD ANGLE PROJECTION</p>	GENERAL TOLERANCES (UNLESS SPECIFIED)		APPROVE BY	DATE	PART NO.	ITEM NO.	<p>3K-KAMING</p>
	X.±.012(0.30)	X.'±5'	FRANK	17/DEC/19	FPH12747-DXXSXXXXXXXXXOM	FPH12747	
	X.X±.008(0.20)	.X'±2'	CHECKED BY	DATE	TITLE		
	X.XX±.006(0.15)	.XX'±1'	CHERRY	17/DEC/19	Board to Board(Pin Header) Pitch 1.27mm 180° Vertical(SMT)		
SCALE	SIZE	X.XXX±.004(0.10)	.XXX'±0.5'	DRAWN BY	DATE	THIS DRAWING CONTAINS INFORMATION THAT IS PROPRIETARY TO DONG GUAN LANG LUN(3K-KAMING) ELECTRONIC PRODUCTS CO.,LTD. AND SHOULD NOT BE USED WITHOUT WRITTEN PERMISSION	
5:1	A4			ZOEY	17/DEC/19	REV 0	SHEET NO. 2/3



REV	LOCATIONS	DESCRIPTION	DATE	REVISER	APPD

Circuits (n)	Part No.	Dimensions(in/mm)			Circuits (n)	Part No.	Dimensions(in/mm)		
		A	B	C			A	B	C
6	FPH12747-D06SXXXXXXXXXOM	.100(2.54)	.150(3.81)	.050(1.27)	46	FPH12747-D46SXXXXXXXXXOM	1.100(27.94)	1.150(29.21)	1.050(26.67)
8	FPH12747-D08SXXXXXXXXXOM	.150(3.81)	.200(5.08)	.100(2.54)	48	FPH12747-D48SXXXXXXXXXOM	1.150(29.21)	1.200(30.48)	1.100(27.94)
10	FPH12747-D10SXXXXXXXXXOM	.200(5.08)	.250(6.35)	.150(3.81)	50	FPH12747-D50SXXXXXXXXXOM	1.200(30.48)	1.250(31.75)	1.150(29.21)
12	FPH12747-D12SXXXXXXXXXOM	.250(6.35)	.300(7.62)	.200(5.08)	52	FPH12747-D52SXXXXXXXXXOM	1.250(31.75)	1.300(33.02)	1.200(30.48)
14	FPH12747-D14SXXXXXXXXXOM	.300(7.62)	.350(8.89)	.250(6.35)	54	FPH12747-D54SXXXXXXXXXOM	1.300(33.02)	1.350(34.29)	1.250(31.75)
16	FPH12747-D16SXXXXXXXXXOM	.350(8.89)	.400(10.16)	.300(7.62)	56	FPH12747-D56SXXXXXXXXXOM	1.350(34.29)	1.400(35.56)	1.300(33.02)
18	FPH12747-D18SXXXXXXXXXOM	.400(10.16)	.450(11.43)	.350(8.89)	58	FPH12747-D58SXXXXXXXXXOM	1.400(35.56)	1.450(36.83)	1.350(34.29)
20	FPH12747-D20SXXXXXXXXXOM	.450(11.43)	.500(12.70)	.400(10.16)	60	FPH12747-D60SXXXXXXXXXOM	1.450(36.83)	1.500(38.10)	1.400(35.56)
22	FPH12747-D22SXXXXXXXXXOM	.500(12.70)	.550(13.97)	.450(11.43)	62	FPH12747-D62SXXXXXXXXXOM	1.500(38.10)	1.550(39.37)	1.450(36.83)
24	FPH12747-D24SXXXXXXXXXOM	.550(13.97)	.600(15.24)	.500(12.70)	64	FPH12747-D64SXXXXXXXXXOM	1.550(39.37)	1.600(40.64)	1.500(38.10)
26	FPH12747-D26SXXXXXXXXXOM	.600(15.24)	.650(16.51)	.550(13.97)	66	FPH12747-D66SXXXXXXXXXOM	1.600(40.64)	1.650(41.91)	1.550(39.37)
28	FPH12747-D28SXXXXXXXXXOM	.650(16.51)	.700(17.78)	.600(15.24)	68	FPH12747-D68SXXXXXXXXXOM	1.650(41.91)	1.700(43.18)	1.600(40.64)
30	FPH12747-D30SXXXXXXXXXOM	.700(17.78)	.750(19.05)	.650(16.51)	70	FPH12747-D70SXXXXXXXXXOM	1.700(43.18)	1.750(44.45)	1.650(41.91)
32	FPH12747-D32SXXXXXXXXXOM	.750(19.05)	.800(20.32)	.700(17.78)	72	FPH12747-D72SXXXXXXXXXOM	1.750(44.45)	1.800(45.72)	1.700(43.18)
34	FPH12747-D34SXXXXXXXXXOM	.800(20.32)	.850(21.59)	.750(19.05)	74	FPH12747-D74SXXXXXXXXXOM	1.800(45.72)	1.850(46.99)	1.750(44.45)
36	FPH12747-D36SXXXXXXXXXOM	.850(21.59)	.900(22.86)	.800(20.32)	76	FPH12747-D76SXXXXXXXXXOM	1.850(46.99)	1.900(48.26)	1.800(45.72)
38	FPH12747-D38SXXXXXXXXXOM	.900(22.86)	.950(24.13)	.850(21.59)	78	FPH12747-D78SXXXXXXXXXOM	1.900(48.26)	1.950(49.53)	1.850(46.99)
40	FPH12747-D40SXXXXXXXXXOM	.950(24.13)	1.00(25.40)	.900(22.86)	80	FPH12747-D80SXXXXXXXXXOM	1.950(49.53)	2.000(50.80)	1.900(48.26)
42	FPH12747-D42SXXXXXXXXXOM	1.000(25.40)	1.050(26.67)	.950(24.13)	100	FPH12747-D100SXXXXXXXXXOM	2.450(62.23)	2.500(63.50)	2.400(60.96)
44	FPH12747-D44SXXXXXXXXXOM	1.050(26.67)	1.100(27.94)	1.000(25.40)					



 THIRD ANGLE PROJECTION	GENERAL TOLERANCES (UNLESS SPECIFIED)		APPROVE BY	DATE	PART NO.	ITEM NO.	 3K-KAMI NG
	X.±.012(0.30)	X.±5'	FRANK	17/DEC/19	FPH12747-DXXSXXXXXXXXXOM	FPH12747	
	X.X±.008(0.20)	X.±2'	CHECKED BY	DATE	TITLE		
	X.XX±.006(0.15)	.XX±1'	CHERRY	17/DEC/19	Board to Board(Pin Header) Pitch 1.27mm 180° Vertical(SMT)		
SCALE 5:1	SIZE A2	X.XXX±.004(0.10)	.XXX±0.5'	DRAWN BY	DATE	REV 0	SHEET NO. 3/3
			ZO EY	17/DEC/19	THIS DRAWING CONTAINS INFORMATION THAT IS PROPRIETARY TO DONG GUAN LANG LUN(3K-KAMI NG) ELECTRONIC PRODUCTS CO.,LTD. AND SHOULD NOT BE USED WITHOUT WRITTEN PERMISSION		