

REV	LOCATIONS	DESCRIPTION	DATE	REVISER	APPD



**SPECIFICATIONS**

**Electrical**

Current Rating: 1.0A AC(rms)/DC  
 Contact Resistance: 20 mΩ Max  
 Insulation Resistance: 1000 MΩ MIN  
 Withstanding Voltage: 500V AC/Minute  
 Operating Temperature: -40°C~+105°C

**Material**

Housing: PA6T (UL 94V-0)  
 Pin: Brass  
 Pin Plating: Gold plated/ Selective gold plated on contact area and 120μ" Min. matte tin plated on tails area  
 Max.Processing Temp: 230°C for 30-60Seconds (260°C for 10 Seconds)

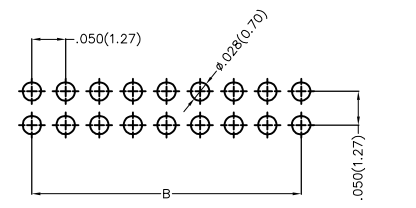
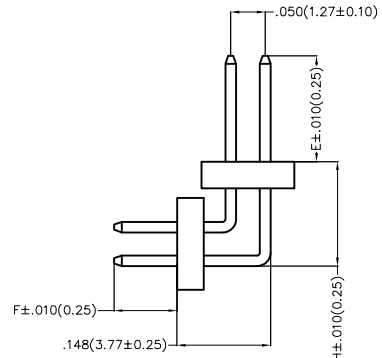
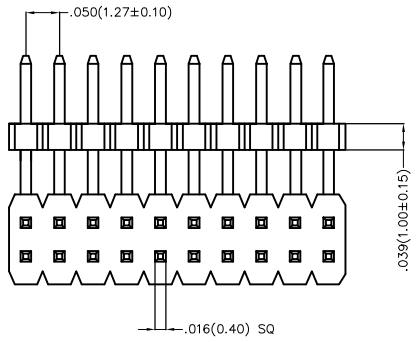
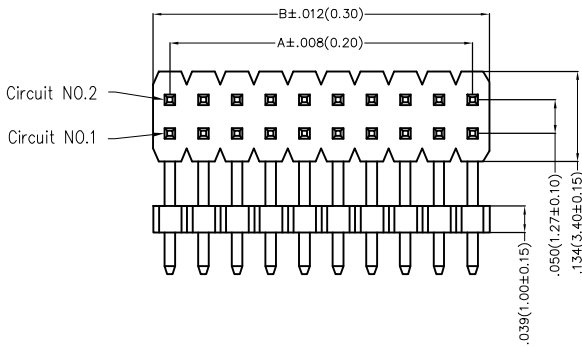

Recommended P.C.Board Layout  
 Tolerances: ±.002(0.05)

**Ordering Information**

FPH 127 45 - D XX B X XX 4 XX XX XX B  
 1 2 3 4 5 6 7 8 9 10 11 12 13

1 Category FPH-Pin Header	2 Series Number 127-Pitch1.27mm	3 Distinction No. 45	4 Row Option D-Double Row	5 Circuits XX	6 Entry Angle B-90° Angle	7 Plating 1-Gold plated 7-Selective gold plated on contact area and matte tin plated on tails area
------------------------------	------------------------------------	-------------------------	------------------------------	------------------	------------------------------	--

9 Thickness of Plating 01-1μ" 15-15μ" Custom plate available	10 Material-Resin 4-PA6T	11 E Size 01,02...-Serial number (See Table1)	12 F Size 01,02...-Serial number (See Table1)	13 H Size 01,02...-Serial number (See Table1)	14 Packaging B-PE Bag
---	-----------------------------	---	---	---	--------------------------

 THIRD ANGLE PROJECTION DESIGN UNITS Inch (metric) SCALE 5:1 SIZE A/L	GENERAL TOLERANCES (UNLESS SPECIFIED) X.±.014(0.35) X.±5' X.X±.012(0.30) .X'±2' X.XX±.008(0.20) .XX'±1' X.XXX±.004(0.10) .XXX'±0.5'		APPROVE BY VERNON DATE 17/DEC/19	PART NO. FPH12745-DXXBXXX4XXXXXB ITEM NO. FPH12745	 3K-KAMING® REV 0 SHEET NO. 1/3 THIS DRAWING CONTAINS INFORMATION THAT IS PROPRIETARY TO DONG GUAN LANG LUN(3K-KAMING) ELECTRONIC PRODUCTS CO.,LTD. AND SHOULD NOT BE USED WITHOUT WRITTEN PERMISSION
	CHECKED BY KATE DATE 17/DEC/19		TITLE Board to Board(Pin Header) Pitch 1.27mm 90° Angle(DIP)		
	DRAWN BY ZOEY DATE 17/DEC/19		DATE 17/DEC/19		

REV	LOCATIONS	DESCRIPTION	DATE	REVISER	APPD

Table1

Serial number	Dimensions (in/mm) E	Serial number	Dimensions (in/mm) E
01	.059(1.50)	19	.236(6.00)
02	.069(1.75)	20	.246(6.25)
03	.079(2.00)	21	.256(6.50)
04	.089(2.25)	22	.266(6.75)
05	.098(2.50)	23	.276(7.00)
06	.108(2.75)	24	.285(7.25)
07	.118(3.00)	25	.295(7.50)
08	.128(3.25)	26	.305(7.75)
09	.138(3.50)	27	.315(8.00)
10	.148(3.75)	28	.325(8.25)
11	.157(4.00)	29	.335(8.50)
12	.167(4.25)	30	.344(8.75)
13	.177(4.50)	31	.354(9.00)
14	.187(4.75)	32	.364(9.25)
15	.197(5.00)	33	.374(9.50)
16	.207(5.25)	34	.384(9.75)
17	.217(5.50)	35	.394(10.00)
18	.226(5.75)		

Serial number	Dimensions (in/mm) F	Serial number	Dimensions (in/mm) F
01	.059(1.50)	19	.236(6.00)
02	.069(1.75)	20	.246(6.25)
03	.079(2.00)	21	.256(6.50)
04	.089(2.25)	22	.266(6.75)
05	.098(2.50)	23	.276(7.00)
06	.108(2.75)	24	.285(7.25)
07	.118(3.00)	25	.295(7.50)
08	.128(3.25)	26	.305(7.75)
09	.138(3.50)	27	.315(8.00)
10	.148(3.75)	28	.325(8.25)
11	.157(4.00)	29	.335(8.50)
12	.167(4.25)	30	.344(8.75)
13	.177(4.50)	31	.354(9.00)
14	.187(4.75)	32	.364(9.25)
15	.197(5.00)	33	.374(9.50)
16	.207(5.25)	34	.384(9.75)
17	.217(5.50)	35	.394(10.00)
18	.226(5.75)		

Serial number	Dimensions (in/mm) H	Serial number	Dimensions (in/mm) H
01	.128(3.25)	19	.305(7.75)
02	.138(3.50)	20	.315(8.00)
03	.148(3.75)	21	.325(8.25)
04	.157(4.00)	22	.335(8.50)
05	.167(4.25)	23	.344(8.75)
06	.177(4.50)	24	.354(9.00)
07	.187(4.75)	25	.364(9.25)
08	.197(5.00)	26	.374(9.50)
09	.207(5.25)	27	.384(9.75)
10	.217(5.50)	28	.394(10.00)
11	.226(5.75)		
12	.236(6.00)		
13	.246(6.25)		
14	.256(6.50)		
15	.266(6.75)		
16	.276(7.00)		
17	.285(7.25)		
18	.295(7.50)		

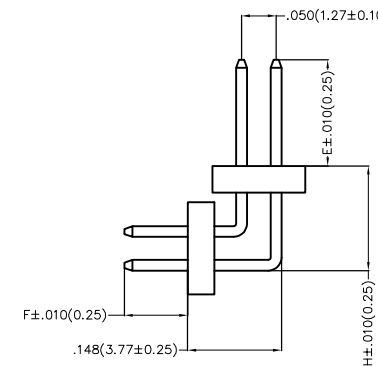

<p>THIRD ANGLE PROJECTION</p>	GENERAL TOLERANCES (UNLESS SPECIFIED)		APPROVE BY VERNON	DATE 17/DEC/19	PART NO. FPH12745-DXXBXXX4XXXXXXB	ITEM NO. FPH12745	<p>3K-KAMING</p>	
	X.±.014(0.35)	X'±5'	CHECKED BY KATE	DATE 17/DEC/19	TITLE Board to Board(Pin Header) Pitch 1.27mm 90° Angle(DIP)			REV 0
	DESIGN UNITS Inch (metric)	X.XX±.012(0.30)	.X'±2'	DRAWN BY ZOEY	DATE 17/DEC/19	THIS DRAWING CONTAINS INFORMATION THAT IS PROPRIETARY TO DONG GUAN LANG LUN(3K-KAMING) ELECTRONIC PRODUCTS CO., LTD. AND SHOULD NOT BE USED WITHOUT WRITTEN PERMISSION		
	SCALE 5:1	X.XX±.008(0.20)	.XX'±1'					

REV	LOCATIONS	DESCRIPTION	DATE	REVISER	APPD



Circuits (n)	Part No.	Dimensions(in/mm)		Circuits (n)	Part No.	Dimensions(in/mm)	
		A	B			A	B
2	FPH12745-D02BXXX4XXXXXXB	-	.050(1.27)	28	FPH12745-D28BXXX4XXXXXXB	.650(16.51)	.700(17.78)
4	FPH12745-D04BXXX4XXXXXXB	.050(1.27)	.100(2.54)	30	FPH12745-D30BXXX4XXXXXXB	.700(17.78)	.750(19.05)
6	FPH12745-D06BXXX4XXXXXXB	.100(2.54)	.150(3.81)	32	FPH12745-D32BXXX4XXXXXXB	.750(19.05)	.800(20.32)
8	FPH12745-D08BXXX4XXXXXXB	.150(3.81)	.200(5.08)	34	FPH12745-D34BXXX4XXXXXXB	.800(20.32)	.850(21.59)
10	FPH12745-D10BXXX4XXXXXXB	.200(5.08)	.250(6.35)	36	FPH12745-D36BXXX4XXXXXXB	.850(21.59)	.900(22.86)
12	FPH12745-D12BXXX4XXXXXXB	.250(6.35)	.300(7.62)	38	FPH12745-D38BXXX4XXXXXXB	.900(22.86)	.950(24.13)
14	FPH12745-D14BXXX4XXXXXXB	.300(7.62)	.350(8.89)	40	FPH12745-D40BXXX4XXXXXXB	.950(24.13)	1.000(25.40)
16	FPH12745-D16BXXX4XXXXXXB	.350(8.89)	.400(10.16)	42	FPH12745-D42BXXX4XXXXXXB	1.000(25.40)	1.050(26.67)
18	FPH12745-D18BXXX4XXXXXXB	.400(10.16)	.450(11.43)	44	FPH12745-D44BXXX4XXXXXXB	1.050(26.67)	1.100(27.94)
20	FPH12745-D20BXXX4XXXXXXB	.450(11.43)	.500(12.70)	46	FPH12745-D46BXXX4XXXXXXB	1.100(27.94)	1.150(29.21)
22	FPH12745-D22BXXX4XXXXXXB	.500(12.70)	.550(13.97)	48	FPH12745-D48BXXX4XXXXXXB	1.150(29.21)	1.200(30.48)
24	FPH12745-D24BXXX4XXXXXXB	.550(13.97)	.600(15.24)	50	FPH12745-D50BXXX4XXXXXXB	1.200(30.48)	1.250(31.75)
26	FPH12745-D26BXXX4XXXXXXB	.600(15.24)	.650(16.51)				



<p>THIRD ANGLE PROJECTION</p>	GENERAL TOLERANCES (UNLESS SPECIFIED)		APPROVE BY	DATE	PART NO.	ITEM NO.	<p>3K-KAMING</p>	
	X.±.014(0.35)	X.±5'	VERNON	17/DEC/19	FPH12745-DXXBXXX4XXXXXXB	FPH12745		
	X.X±.012(0.30)	.X'±2'	CHECKED BY	DATE	TITLE Board to Board(Pin Header) Pitch 1.27mm 90° Angle(DIP)			
DESIGN UNITS Inch (metric)	X.XX±.008(0.20)	.XX±1'	KATE	17/DEC/19			REV 0	SHEET NO. 3/3
SCALE 5:1	SIZE A<	X.XXX±.004(0.10)	.XXX±0.5'	DRAWN BY	DATE	THIS DRAWING CONTAINS INFORMATION THAT IS PROPRIETARY TO DONG GUAN LANG LUN(3K-KAMING) ELECTRONIC PRODUCTS CO.,LTD. AND SHOULD NOT BE USED WITHOUT WRITTEN PERMISSION		
			ZOEY	17/DEC/19				