

Assembly Layout

C	Solder Tab	2 PCS	PhosphorBronze	Sn-plated
B	CONTACT	1~16 PCS	Brass	Sn-plated
A	HOUSING	1 PCS	LCP	UL 94V-0, COLOR:BEIGE
ITEM	COMPONENT	Q'TY	MATERIAL	FINISH

Circuit	Dimensions (mm)			
	A	B	C	D
02	2.50	7.50	10.00	6.00
03	5.00	10.00	12.50	8.50
04	7.50	12.50	15.00	11.00
05	10.00	15.00	17.50	13.50
06	12.50	17.50	20.00	16.00
07	15.00	20.00	22.50	18.50
08	17.50	22.50	25.00	21.00
09	20.00	25.00	27.50	23.50
10	22.50	27.50	30.00	26.00
11	25.00	30.00	32.50	28.50
12	27.50	32.50	35.00	31.00
13	30.00	35.00	37.50	33.50
14	32.50	37.50	40.00	36.00
15	35.00	40.00	42.50	38.50
16	37.50	42.50	45.00	41.00



主要技术参数 Main Specifications

- 线数 (Poles): 02 to 16
- 接触电阻 (Contact resistance):  $\leq 20m\Omega$
- 绝缘电阻 (Insulation resistance):  $\geq 1000M\Omega$
- 额定电压 (Rated voltage): 250V AC DC
- 额定电流 (Rated current): 3.0A AC DC
- 耐电压 (Withstand Voltage): 1000V AC/minute
- 温度范围 (Temperature Range):  $-25^{\circ}C \sim +105^{\circ}C$

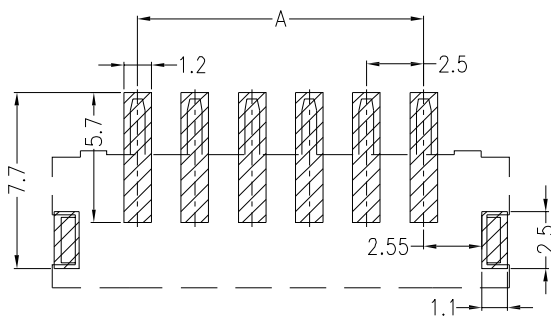

SUGGESTED PCB LAYOUT

UNITS	mm	东莞市朗纶电子制品有限公司 Dongguan langlun electronic products Co., Ltd				
MAT'L		PART NO.(INTENDED USE)	TITLE:			
		XH2. 54-2ABK	XH2. 54立贴2P带扣			
FINISH		APPD:	DWG NO.:			
			XH2. 54-2ABK			
Q'TY	PCS	CHKD:		SCALE	SHEET	REV.
		DR: HU 2016.09.28		1/1	1/1	A

X.± 0.3	X°± 5°
.X± 0.25	.X°± 2°
.XX± 0.20	.XX°± 1°
.XXX± 0.10	.XXX°± 0.5°