

1 2 3 4 5 6 7 8

REV	LOCATIONS	DESCRIPTION	DATE	REVISER	APPD
1	△	Part No.: Change FRJ45119 into FRJ45036	31/MAY/18	KATE	ERIC
2	△	1. Structure change, 2. Tolerances change	20/APR/20	KATE	CHERRY

A
B
C
D
E
F

A
B
C
D
E
F

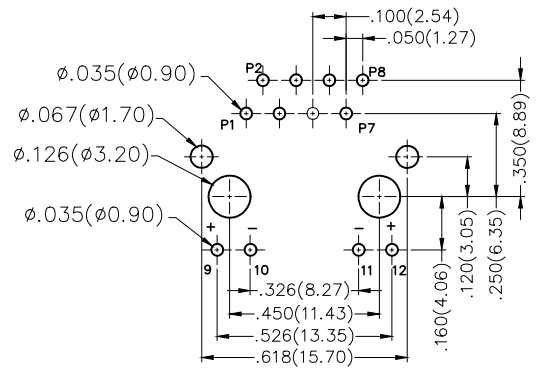

Recommended P.C.Board Layout
Tolerances: ±.002(0.05)



SPECIFICATIONS

Electrical
 Current Rating: 1.5A AC(rms)/DC
 Voltage Rating: 150V AC(rms)/DC
 Contact Resistance: 30 mΩ Max
 Insulation Resistance: 500 MΩ Min / DC 500V
 Withstanding Voltage: 1000V AC r.m.s
 Operating Temperature: -40°C~+85°C

Material and Plating
 Housing: PA46, 94V-0 ,Black
 Contact: Phosphor Bronze/Gold Plated/Selective gold
 in contact area, tin on tail
 Shell: Brass/Nickel Plated

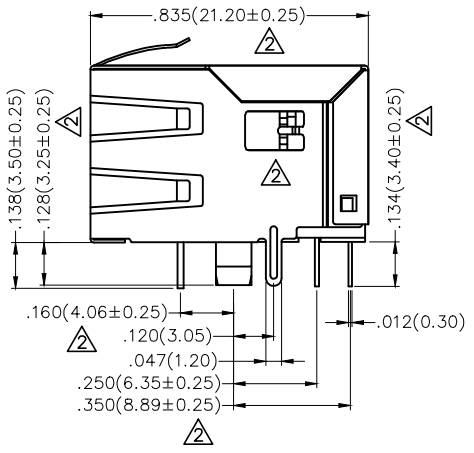
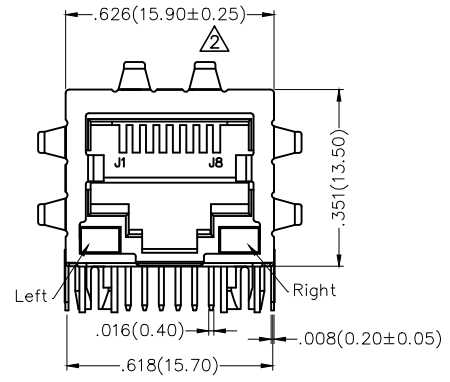

Ordering Information

FRJ45 036 — 1 3 XX K6 K X 1 A 1
 1 2 3 4 5 6 7 8 9 10 11

1 Category FRJ45-RJ45 Connector	2 Distinction No. 036	3 Ports options 1-1 Port	4 Plating 3-Selective gold in contact area, tin on tail	5 Thickness of plating 00-Gold flash 03-3μ" Custom plate available
6 Color-Resin K6-Black	7 Packaging K-Tray	8 LED style 1-L: Yellow R: Green 2-L: Green R: Yellow	9 Contact type 1-Square pin	10 distinction type A-A type
		11 Pin circuits 1-100Base-T		

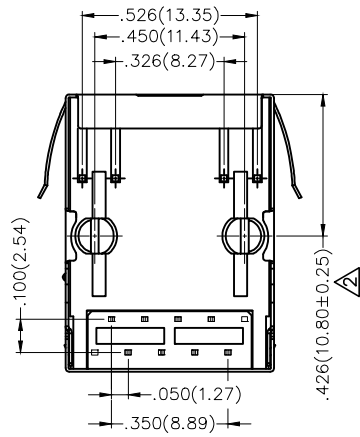

THIRD ANGLE PROJECTION	GENERAL TOLERANCES (UNLESS SPECIFIED)		APPROVE BY FRANK	DATE 18/JUN/13	PART NO. △ FRJ45036-13XXK6KX1A1	ITEM NO. FRJ45036		
	X.±.012(0.30)	X.±5°	CHECKED BY KEVIN	DATE 18/JUN/13	TITLE RJ45 Connectors 8P8C 90°Angle(100Base-T)			
DESIGN UNITS Inch (metric)	X.X±.008(0.20)	X.±2°	DRAWN BY CHERRY	DATE 18/JUN/13	THIS DRAWING CONTAINS INFORMATION THAT IS PROPRIETARY TO DONG GUAN LANG LUN(3K-KAMING) ELECTRONIC PRODUCTS CO., LTD. AND SHOULD NOT BE USED WITHOUT WRITTEN PERMISSION		REV 2	SHEET NO. 1/2
SCALE 5:1	SIZE A4	X.XX±.006(0.15)						
		X.XXX±.004(0.10)						

1 2 3 4 5 6 7 8

REV	LOCATIONS	DESCRIPTION	DATE	REVISER	APPD

Schematic



Parameter	Specifications
Turns Ratio	1:1±3%
Inductance(OCL)	350uH Min@100KHz/100mV With 8mA DC Bias
Insertion Loss	-1.0dB MAX@0.3MHz-100MHz;
Return Loss (Z out=100 OHM)	-18dB Min@1MHz-30MHz; -13dB Min@30MHz-60MHz -10dB Min@60MHz-100MHz
Cross Talk (Adjacent Channels)	-30dB Min@1MHz-100MHz
Common Mode Rejection Ratio	-30dB Min@1MHz-100MHz
HI-POT	500VAC

LED SPECIFICATION			
STANDARD LED	WAVELENGTH	Forward V(max)	TYP
GREEN	565nm	2.4V	2.2V
YELLOW	590nm	2.5V	2.1V

* With A Forward Current of 20mA

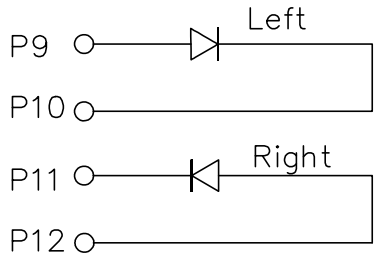
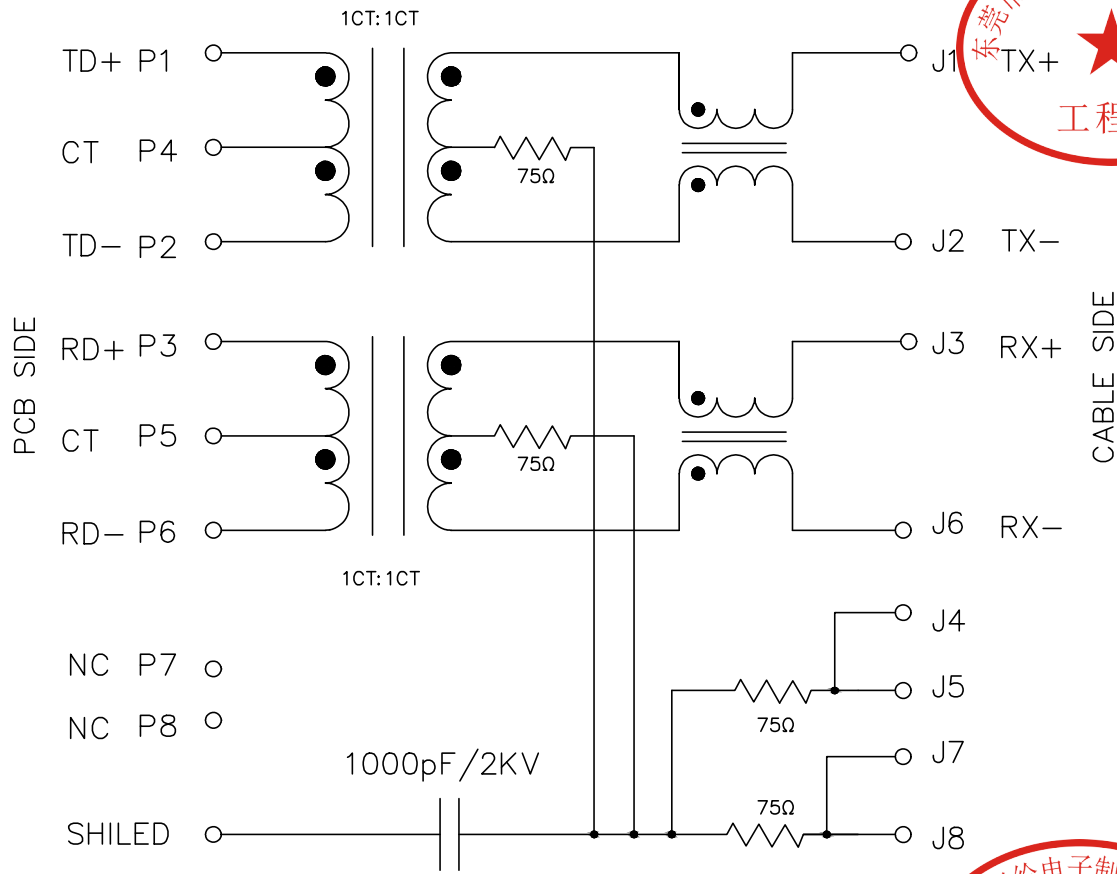

<p>THIRD ANGLE PROJECTION</p>	GENERAL TOLERANCES (UNLESS SPECIFIED)		APPROVE BY FRANK	DATE 18/JUN/13	PART NO. FRJ45036-13XXK6KX1A1	ITEM NO. FRJ45036	<p>3K-KAMING</p>		
	X.±.012(0.30)	X.±5'	CHECKED BY KEVIN	DATE 18/JUN/13	TITLE RJ45 Connectors 8P8C 90°Angle(100Base-T)			REV 2	SHEET NO. 2/2
	X.X±.008(0.20)	.X'±2'	DRAWN BY CHERRY	DATE 18/JUN/13	THIS DRAWING CONTAINS INFORMATION THAT IS PROPRIETARY TO DONG GUAN LANG LUN(3K-KAMING) ELECTRONIC PRODUCTS CO., LTD. AND SHOULD NOT BE USED WI THOUT WRITTEN PERMISSION				
DESIGN UNITS Inch (metric)	X.XX±.006(0.15)	.XX'±1'							
SCALE 5:1	SIZE A4	X.XXX±.004(0.10)	.XXX±0.5'						

1 2 3 4 5 6 7 8

REV	LOCATIONS	DESCRIPTION	DATE	REVISER	APPD
1	△	Part No.: Change FRJ45119 into FRJ45036	31/MAY/18	KATE	ERIC

SPECIFICATIONS

Electrical
 Current Rating: 1.5A AC(rms)/DC
 Voltage Rating: 150V AC(rms)/DC
 Contact Resistance: 30 mΩ Max
 Insulation Resistance: 500 MΩ Min / DC 500V
 Withstanding Voltage: 1000V AC r.m.s
 Operating Temperature: 0°C~+70°C
 Storage Temperature: -40°C~+85°C

Material and Plating
 Housing: PA46, 94V-0 ,Black
 Contact: Phosphor Bronze/Selective gold
 in contact area, tin on tail
 Shell: Brass/Nickel Plated

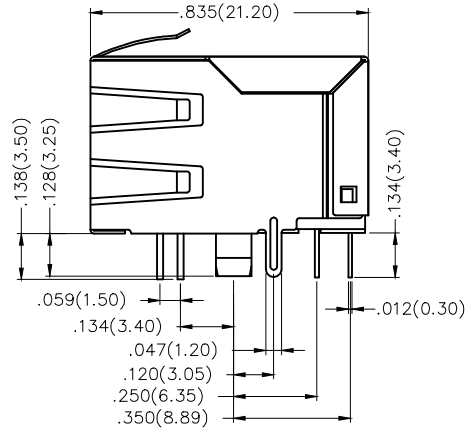
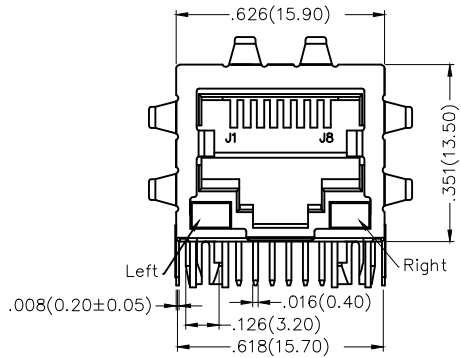
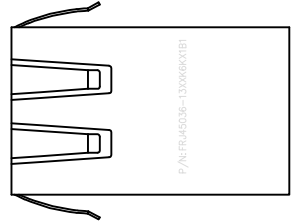
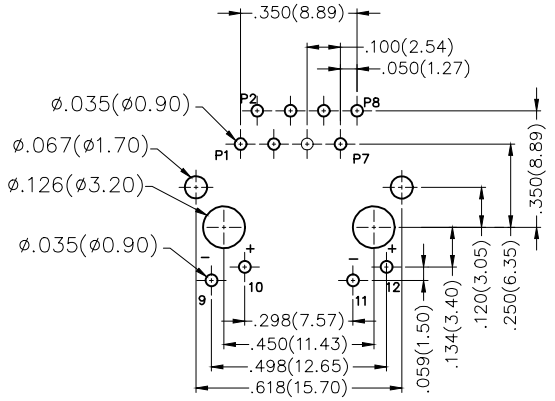

Ordering Information

FRJ45 036 - 1 3 XX K6 K X 1 B 1
 1 2 3 4 5 6 7 8 9 10 11

1 Category FRJ45-RJ45 Connector	2 Distinction No. 036	3 Ports options 1-1 Port	4 Plating 3-Selective gold in contact area, tin on tail	5 Thickness of plating 00-Gold flash 03-3μ" Custom plate available
6 Color-Resin K6-Black	7 Packaging K-Tray	8 LED style 1-L: Yellow R: Green 2-L: Green R: Yellow	9 Contact type 1-Square pin	10 distinction type B-B type
		11 Pin circuits 1-100Base-T		

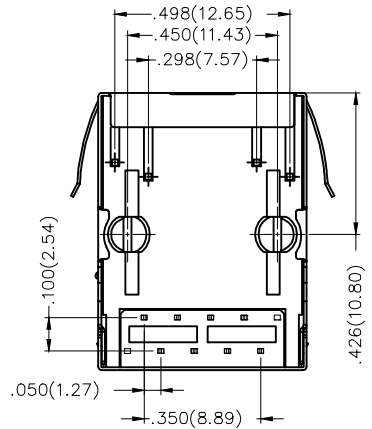

 THIRD ANGLE PROJECTION DESIGN UNITS Inch (metric) SCALE 5:1 SIZE A4	GENERAL TOLERANCES (UNLESS SPECIFIED)		APPROVE BY FRANK	DATE 18/JUN/13	PART NO. △ FRJ45036-13XXK6KX1B1	ITEM NO. FRJ45036	 3K-KAMING REV 1 SHEET NO. 1/2
	X.±.012(0.30)	X.±5'	CHECKED BY KEVIN	DATE 18/JUN/13	TITLE RJ45 Connectors 8P8C 90°Angle(100Base-T)		
	X.X±.008(0.20)	X.±2'	DRAWN BY CHERRY	DATE 18/JUN/13	THIS DRAWING CONTAINS INFORMATION THAT IS PROPRIETARY TO DONG GUAN LANG LUN(3K-KAMING) ELECTRONIC PRODUCTS CO., LTD. AND SHOULD NOT BE USED WITHOUT WRITTEN PERMISSION		
	X.XX±.006(0.15)	.XX±1'					
		X.XXX±.004(0.10)	.XXX±0.5'				

1 2 3 4 5 6 7 8

REV	LOCATIONS	DESCRIPTION	DATE	REVISER	APPD

Schematic

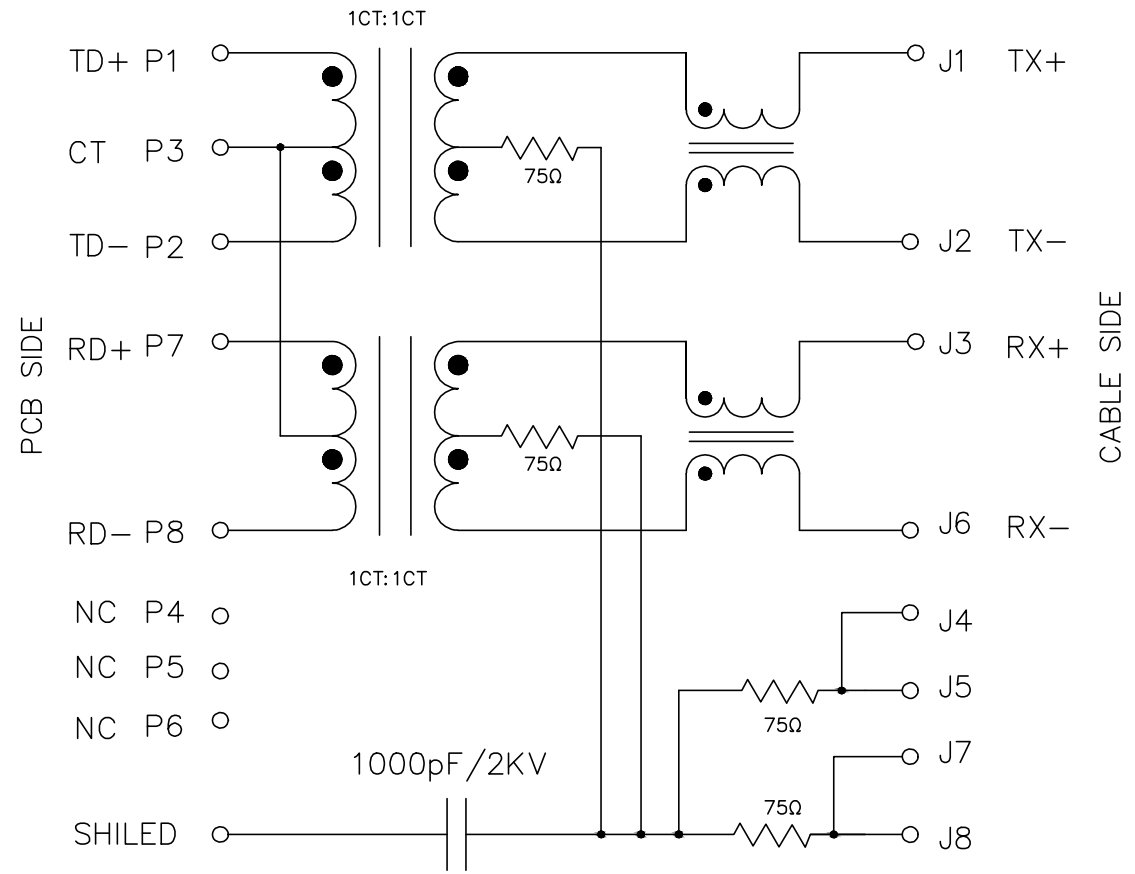

Parameter	Specifications
Turns Ratio	1:1±2%
Inductance(OCL)	350uH Min@100KHz/100mV With 8mA DC Bias
Insertion Loss	-1.0dB MAX@0.3MHz-100MHz;
Return Loss (Z out=100 OHM)	-18dB Min@1MHz-30MHz; -13dB Min@30MHz-60MHz -10dB Min@60MHz-100MHz
Cross Talk (Adjacent Channels)	-30dB Min@1MHz-100MHz
Common Mode Rejection Ratio	-30dB Min@1MHz-100MHz
HI-POT	2250 VDC@60 SECONDS

LED SPECIFICATION			
STANDARD LED	WAVELENGTH	Forward V(max)	TYP
GREEN	565nm	2.4V	2.2V
YELLOW	590nm	2.5V	2.1V

* With A Forward Current of 20mA

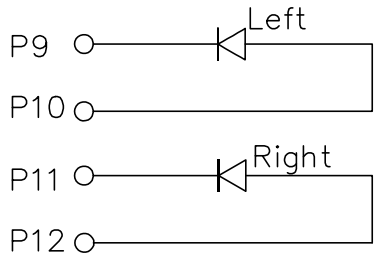

 THIRD ANGLE PROJECTION	GENERAL TOLERANCES (UNLESS SPECIFIED)		APPROVE BY FRANK	DATE 18/JUN/13	PART NO. FRJ45036-13XXK6KX1B1	ITEM NO. FRJ45036	 3K-KAMING		
	X.±.012(0.30)	X.±5'	CHECKED BY KEVIN	DATE 18/JUN/13	TITLE RJ45 Connectors 8P8C 90°Angle(100Base-T)			REV 1	SHEET NO. 2/2
	X.X±.008(0.20)	.X'±2'	DRAWN BY CHERRY	DATE 18/JUN/13	THIS DRAWING CONTAINS INFORMATION THAT IS PROPRIETARY TO DONG GUAN LANG LUN(3K-KAMING) ELECTRONIC PRODUCTS CO., LTD. AND SHOULD NOT BE USED WITHOUT WRITTEN PERMISSION				
DESIGN UNITS Inch (metric)	X.XX±.006(0.15)	.XX'±1'							
SCALE 5:1	SIZE A4	X.XXX±.004(0.10)	.XXX±0.5'						