

Recommended P.C.Board Layout

REV	LOCATIONS	DESCRIPTION	DATE	REVISER	APPD
1	△	1. Dimension: Change 11.90 into 12.15mm 2. Add the "TXGA" logo 3. Part No.: Change FRJ45130 into FRJ45029	31/MAY/18	KATE	ERIC

SPECIFICATIONS

Electrical
 Current Rating: 1.5A AC(rms)/DC
 Voltage Rating: 150V AC(rms)/DC
 Contact Resistance: 40 mΩ Max
 Insulation Resistance: 500 MΩ Min / DC 500V
 Withstanding Voltage: 1000V AC r.m.s
 Operating Temperature: -20°C~+75°C

Material and plating
 Housing: PBT (UL 94V-0), Black
 Contact: Phosphor Bronze/ Gold plated
 Shell: Brass/ Nickel Plated

Ordering Information

FRJ45 029 - 1 1 XX K6 K 0 2 0 0
 1 2 3 4 5 6 7 8

1	Category FRJ45-RJ45 Connector	2	Distinction No. 029	3	Ports options 1-1 Port	4	Plating 1-Gold Plated
5	Thickness of plating 00-Gold flash 03-3μ" Custom plate available	6	Color-Resin K6-Black	7	Packaging K-Tray	8	Contact type 2-Round pin



THIRD ANGLE PROJECTION		GENERAL TOLERANCES (UNLESS SPECIFIED)		APPROVE BY	DATE	PART NO. △	ITEM NO.	3K-KAMING®	
DESIGN UNITS Inch (metric)	X.±.012(0.30)	X.±5°	CHECKED BY	FRANK	09/NOV/16	FRJ45029-11XXK6K0200	FRJ45029	REV 1	SHEET NO. 1/1
	X.X±.008(0.20)	X.±2°	CHECKED BY	CHERRY	09/NOV/16	TITLE RJ45 Connector 8P8C 90° Angle			
	X.XX±.006(0.15)	.XX±1°	DRAWN BY	KATE	09/NOV/16	THIS DRAWING CONTAINS INFORMATION THAT IS PROPRIETARY TO DONG GUAN LANG LUN(3K-KAMING) ELECTRONIC PRODUCTS CO.,LTD. AND SHOULD NOT BE USED WI THOUT WRITTEN PERMISSION			
SCALE 5:1	SIZE A4	X.XXX±.004(0.10)	.XXX±0.5°						

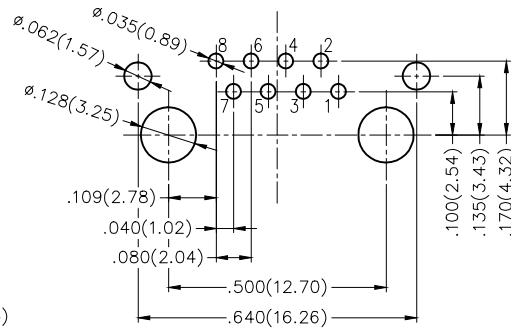
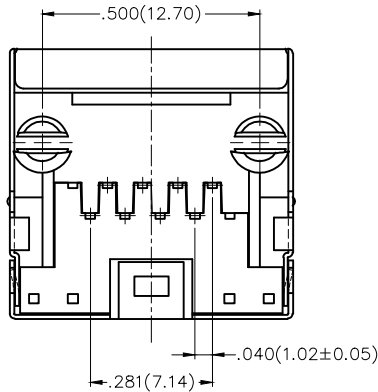
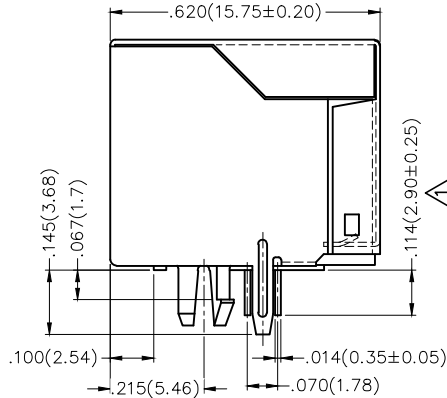
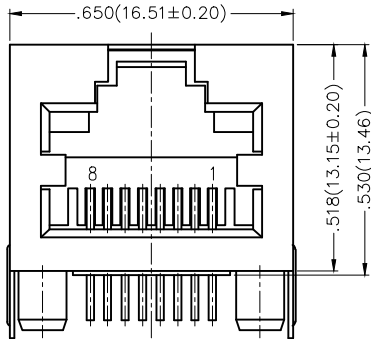
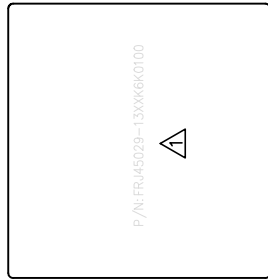

Recommended P.C. Board Layout



REV	LOCATIONS	DESCRIPTION	DATE	REVISER	APPD
1	△	1. Dimension: Change 2.62 into 2.90mm 2. Add the "TXGA" logo 3. Part No.: Change FRJ45130 into FRJ45029	31/MAY/18	KATE	ERIC

SPECIFICATIONS

Electrical

Current Rating: 1.5A AC(rms)/DC
Voltage Rating: 125V AC(rms)/DC
Contact Resistance: 40 mΩ Max
Insulation Resistance: 1000 MΩ Min / DC 500V
Withstanding Voltage: 1000V AC r.m.s
Operating Temperature: -20°C~+75°C

Material

Housing: Thermoplastic UL94V-0, Black
Contact: Phosphor Bronze
Shell: Brass

Plating

Contact: Selective gold in contact area, tin on tail
Shell: Nickel Plated

Ordering Information

FRJ45 029 - 1 3 XX K6 K 0 1 0 0
1 2 3 4 5 6 7 8

1	Category FRJ45-RJ45 Connector	2	Distinction No. 029	3	Ports options 1-1 Port	4	Plating 3-Selective gold in contact area, tin on tail
5	Thickness of plating 00-Gold flash 03-3μ" Custom plate available	6	Color-Resin K6-Black	7	Packaging K-Tray	8	Contact type 1-Square pin

<p>THIRD ANGLE PROJECTION</p>	GENERAL TOLERANCES (UNLESS SPECIFIED)		APPROVE BY FRANK	DATE 09/NOV/16	PART NO. △ FRJ45029-13XXK6K0100	ITEM NO. FRJ45029	<p>3K-KAMING</p>
	DESIGN UNITS Inch (metric)	X.±.012(0.30) X.X±.008(0.20) X.XX±.006(0.15) X.XXX±.004(0.10)	X.±5° .X'±2° .XX'±1° .XXX'±0.5'	CHECKED BY CHERRY	DATE 09/NOV/16	TITLE RJ45 Connector 8P8C 90° Angle	
SCALE 5:1	SIZE A4		DRAWN BY KATE	DATE 09/NOV/16	THIS DRAWING CONTAINS INFORMATION THAT IS PROPRIETARY TO DONG GUAN LANG LUN(3K-KAMING) ELECTRONIC PRODUCTS CO., LTD. AND SHOULD NOT BE USED WITHOUT WRITTEN PERMISSION		REV 1 SHEET NO. 1/1