

△				
△				
△				
△				
ZONE	REV	DESCRIPTION	DATE	APPD.

Order Information:
PJ-351_C
Schematic

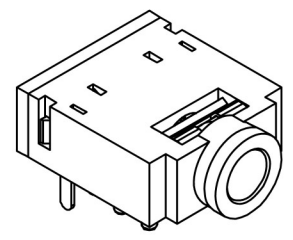

- Specifications:**
1. Rating : 12V DC, 1A
 2. Contact resistance : 50mΩ Max.
 3. Insulation resistance : 500VDC-100MΩ Min.
 4. Withstand voltage : 500VAC-1minute
 5. Insertion and extraction force : 0.3kgs-2.0kgs
 6. Life cycle : 5,000 cycles Min.

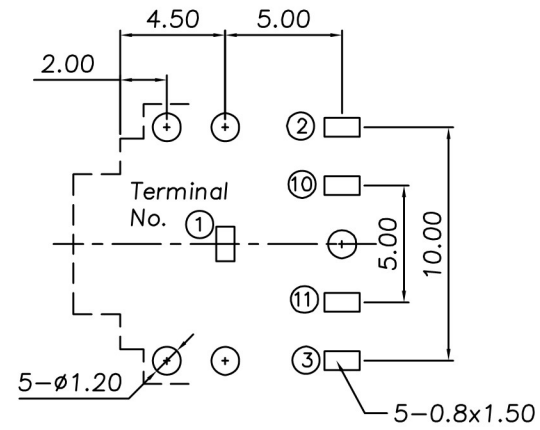
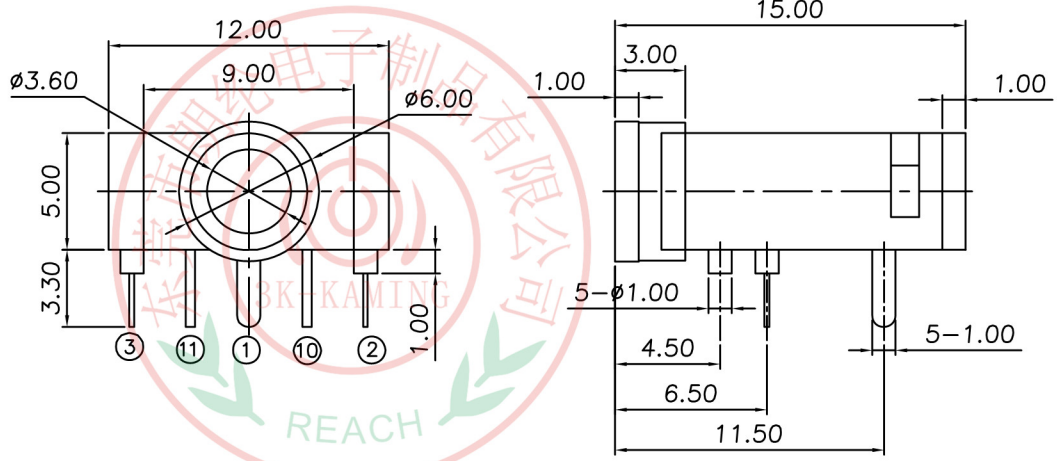
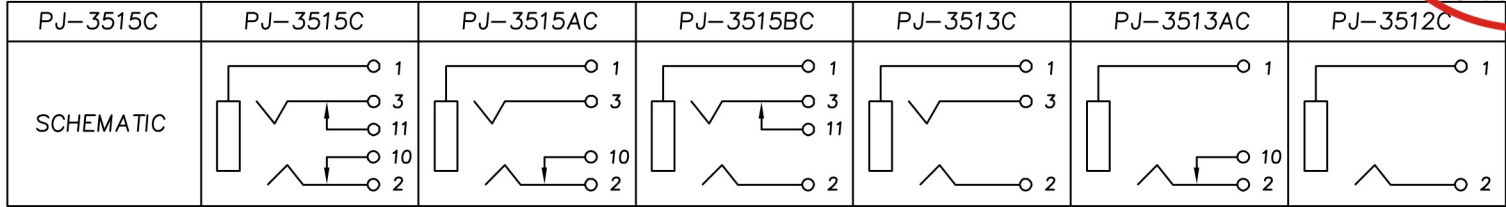
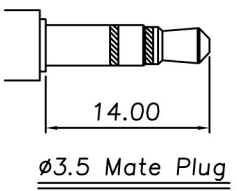

8	Bushing	Brass	1	Ni Plated
7	Terminal 11	Brass	1	Sn Plated
6	Terminal 10	Brass	1	Sn Plated
5	Terminal 3	Copper Alloy	1	Sn Plated
4	Terminal 2	Copper Alloy	1	Sn Plated
3	Terminal 1	Copper Alloy	1	Sn Plated
2	Cover	PBT	1	Black
1	Housing	PBT	1	Black
No.	Part Name	Material	Q"ty	Finishing

东莞市朗纶电子制品有限公司
Dongguan langlun electronic products Co., Ltd
TEL: 86-0769-82123233 FAX: 86-0769-83536433

DESIGN	Will	SCALE		
DRAWING	Will	UNIT	mm	
CHECK	Will	SIZE	A4: 210*297	
APPROVAL	Eric	VERSION	01	

TOLERANCE UNLESS OTHERWISE STATED(mm)	PART NAME	PHONE JACK
less than 10 ±0.2	PART NO	PJ-351C SERIES
10~30 ±0.3	DRAWING NO	
30~100 ±0.5	DATE	2009/11/24
ANGLE ±2'		