

RoHS
Compatible

东莞市朗纶电子制品有限公司
★
受控文件

△				
△				
△				
△				
ZONE	REV	DESCRIPTION	DATE	APPD.

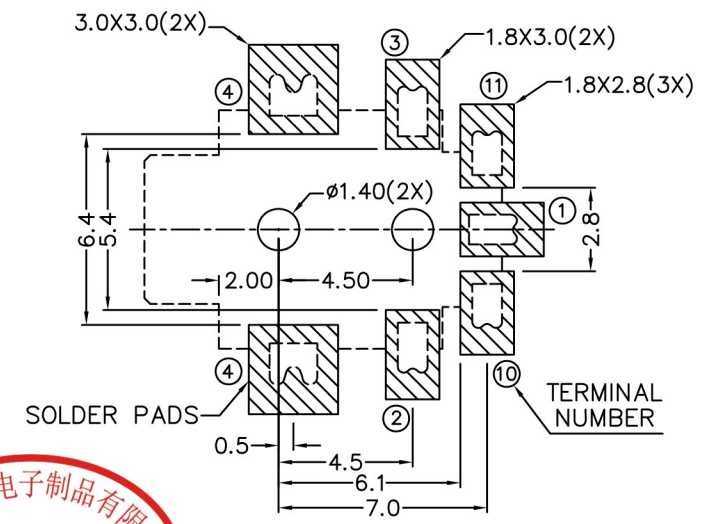
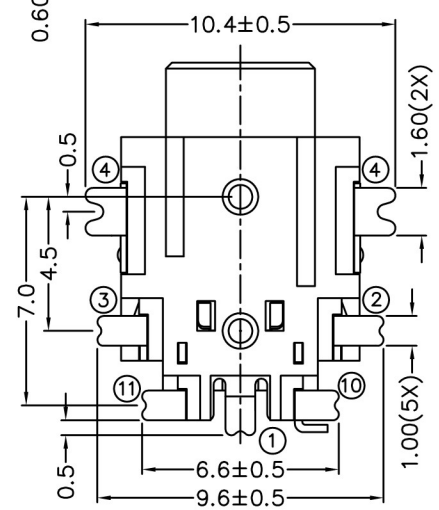
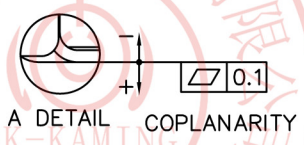
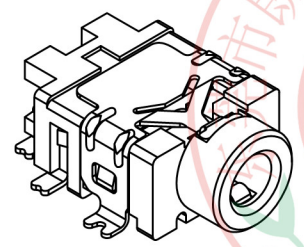
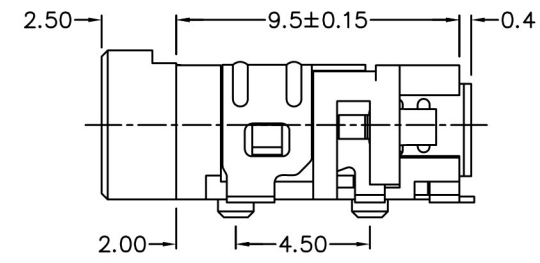
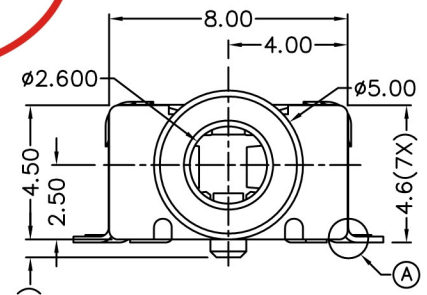
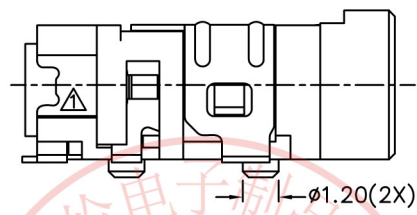

*** MATERIAL**
 TERMINAL 1 : COPPER ALLOY
 TERMINAL 2 : COPPER ALLOY
 TERMINAL 3 : COPPER ALLOY
 TERMINAL 4 : COPPER ALLOY
 TERMINAL 10 : BRASS
 TERMINAL 11 : BRASS
 HOUSING : PA6T

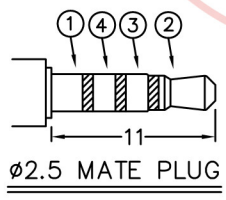

MODEL NO.	PJ-2706D	PJ-2705AD	PJ-2705BD	PJ-2705D	PJ-2704D
SCHEMATIC					

东莞市朗纶电子制品有限公司
★
工程部

3K-KAMING 东莞市朗纶电子制品有限公司
Dongguan langlun electronic products Co., Ltd
TEL: 86-0769-82123233 FAX: 86-0769-83536433

DESIGN	Will	SCALE		
DRAWING	Will	UNIT	mm	
CHECK	Will	SIZE	A4: 210*297	
APPROVAL	Eric	VERSION	01	

TOLERANCE UNLESS OTHERWISE STATED(mm)	PART NAME	PHONE JACK
less than 10 — ±0.3	PART NO	PJ-270D SERIES
10~30 — ±0.4	DRAWING NO	
30~100 — ±0.5	DATE	2012/01/12
ANGIE — ±2'		