



REV	LOCATIONS	DESCRIPTION	DATE	REVISER	APPD

Pin Define

Connector Pin No.	SD Card Pin No.	Pin Define
P1	P9	DAT2
P2	P1	DAT3
P3	P2	CMD
P4		CD
P5	P3	VSS1
P6	P4	VDD
P7	P5	CLK
P8	P6	VSS2
P9	P7	DAT0
P10	P8	DAT1
P11		W/P
P12		GND
P13		GND
P14		GND
P15		GND

SPECIFICATIONS

Electrical
 Current Rating: 0.5A AC(rms)/DC
 Voltage Rating: 100V AC(rms)/DC
 Contact Resistance: 100 mΩ Max
 Insulation Resistance: 1000 MΩ Min/DC 250V
 Withstanding Voltage: 500V AC r.m.s
 Temperature Range-Operating: -25°C~+85°C

Material
 Housing: LCP (UL 94V-0) Black
 Contact: Copper alloy
 Shell: Stainless steel

Plating
 Contact: 1μ" gold in contact area, Matte tin on solder area,
 Nickel plated overall
 Shell: Nickel plated overall

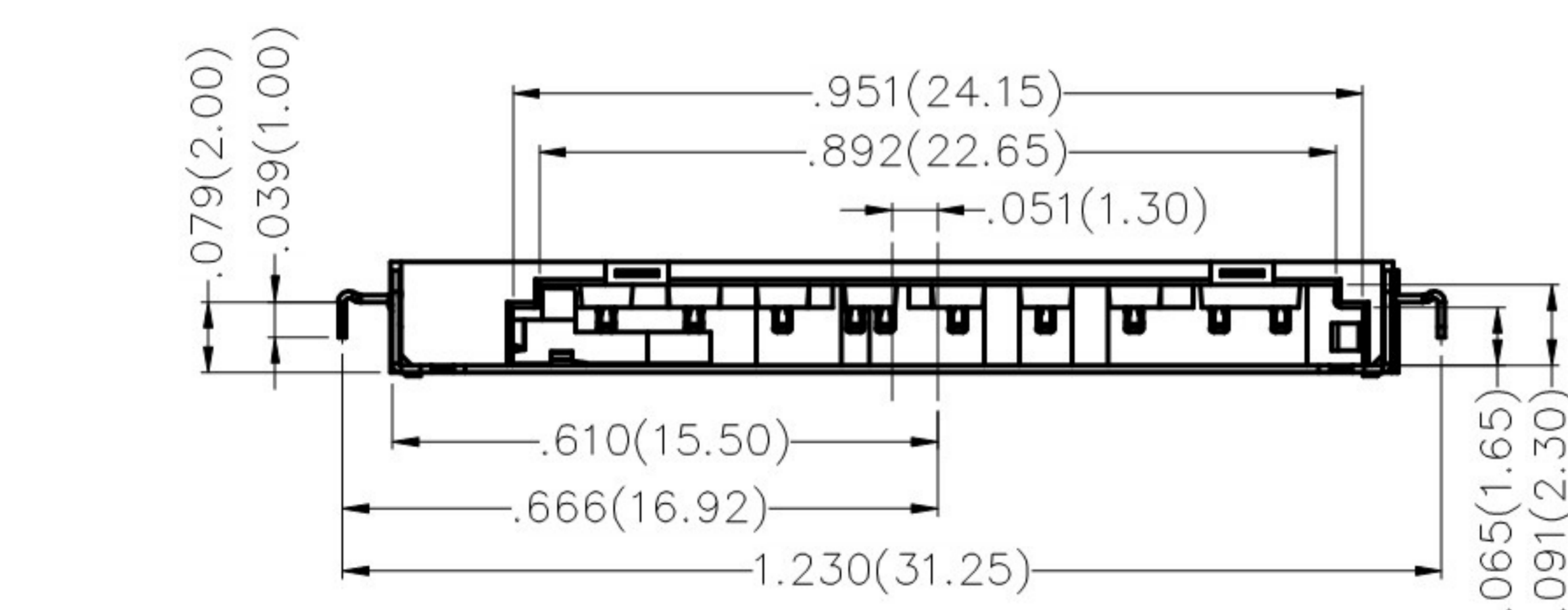
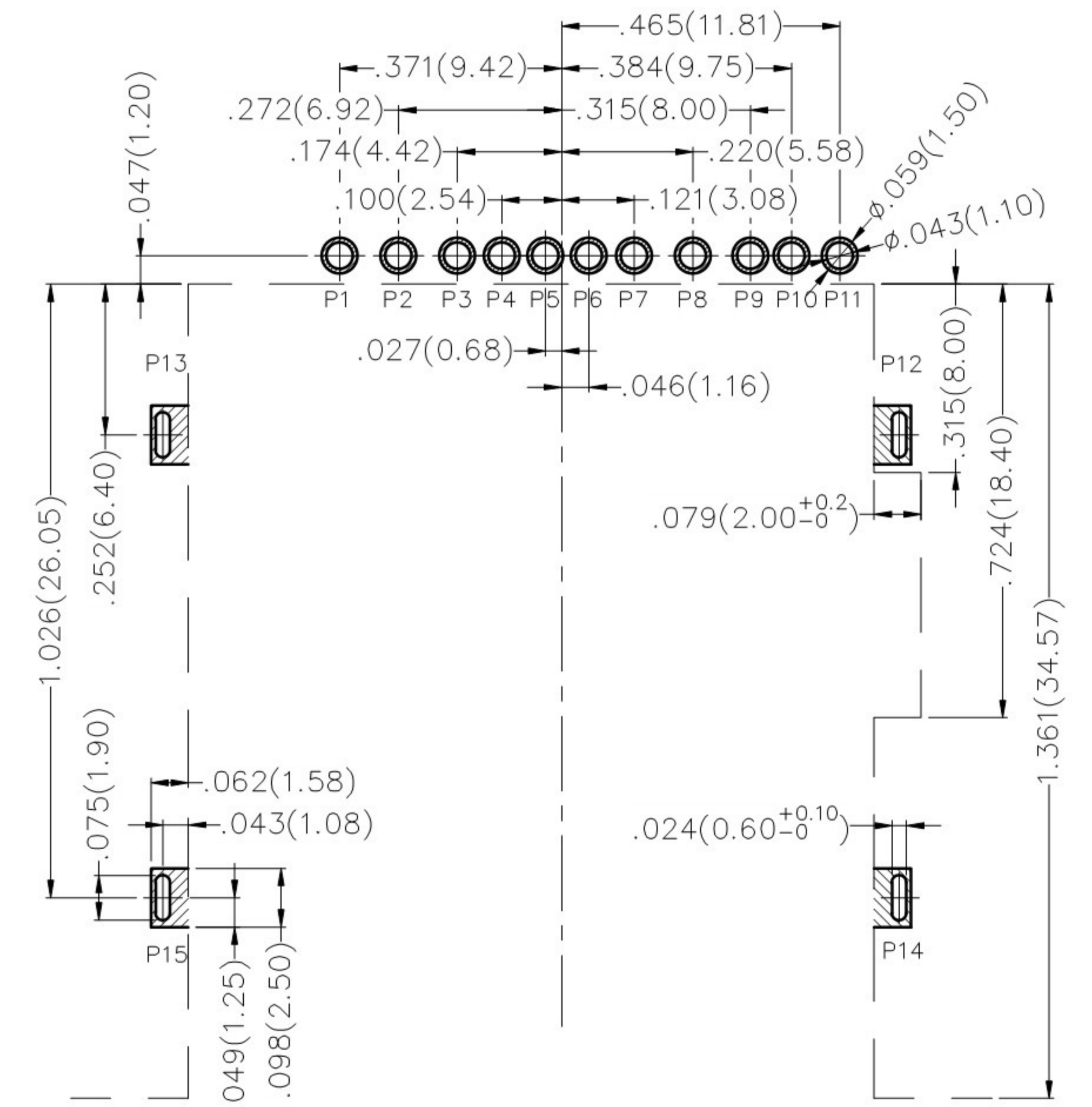
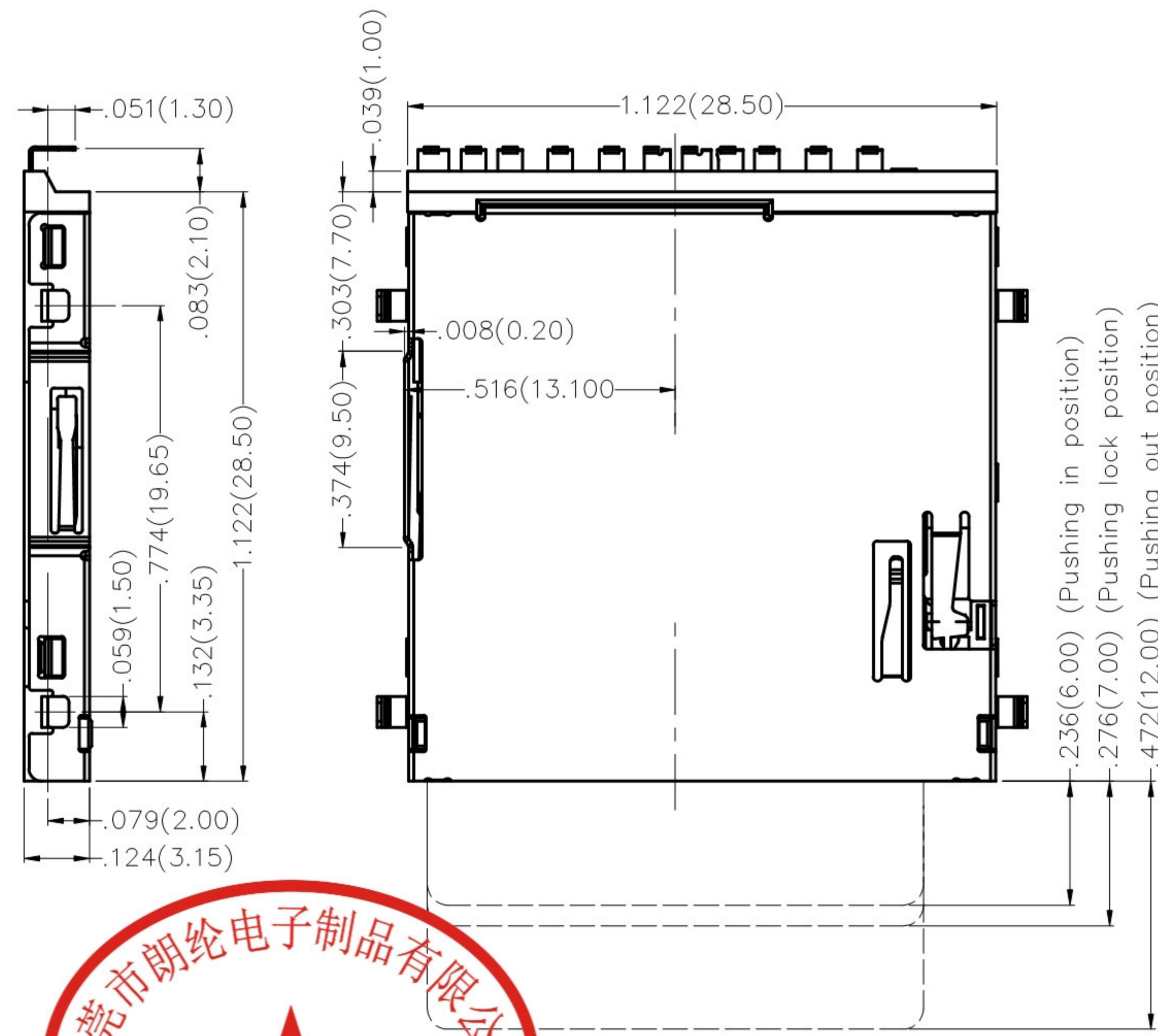
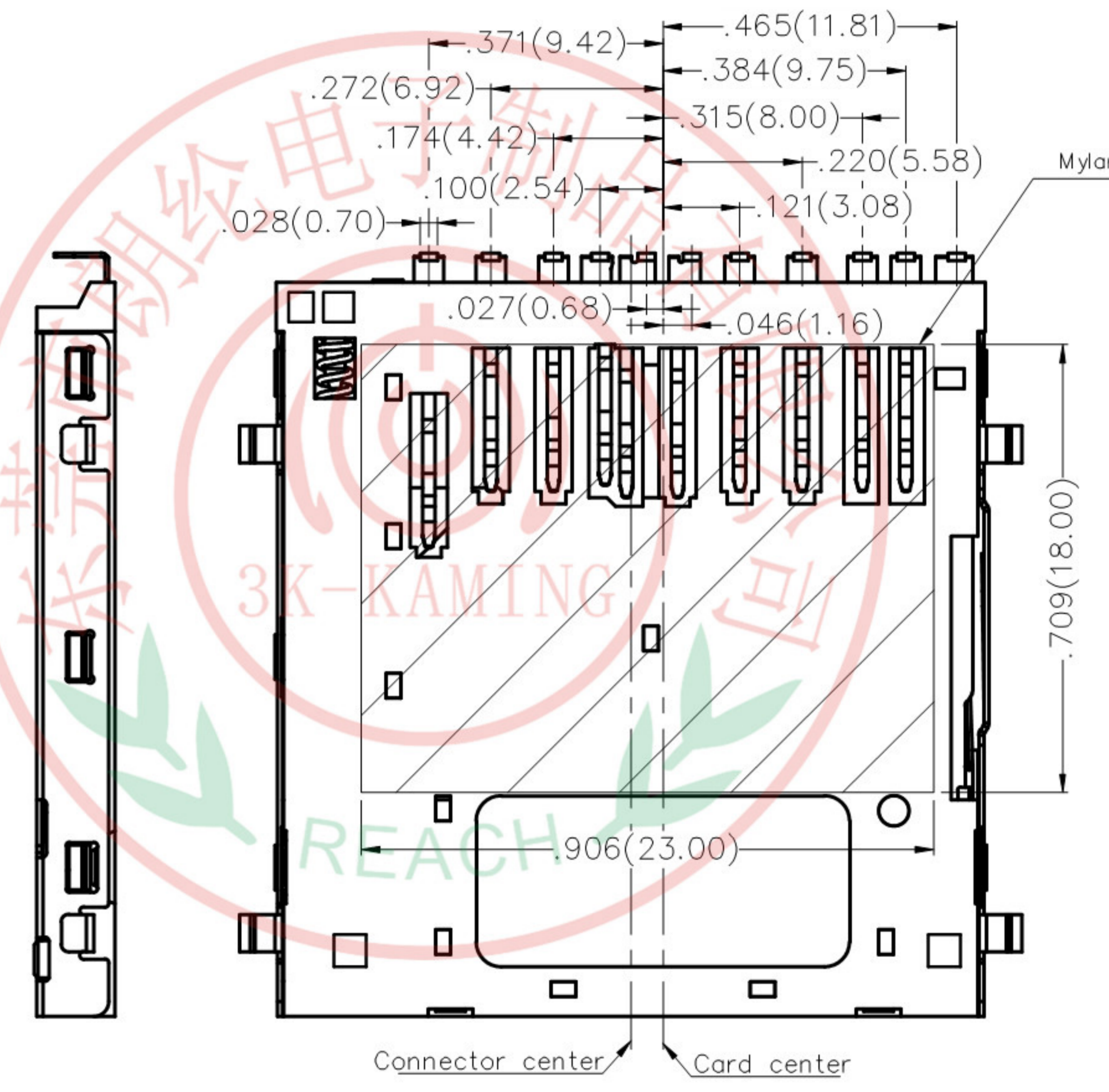
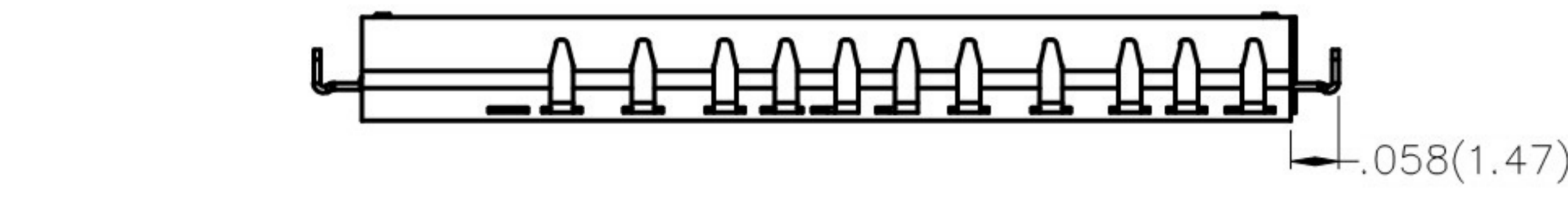

▨ PAD AREA Recommended P.C.Board Layout
 General tolerances: ±.002(0.05)

with out card	CD	○	○	CD
	WP	○	○	WP
inserted card (unlock)	CD	○	○	CD
	WP	○	○	WP
inserted card(lock)	CD	○	○	CD
	WP	○	○	WP

 THIRD ANGLE PROJECTION DESIGN UNITS Inch (metric) SCALE 5:1 SIZE A4	GENERAL TOLERANCES (UNLESS SPECIFIED)		APPROVE BY FRANK	DATE 01/AUG/19	PART NO. FCD133-7M	ITEM NO. FCD133	 3K-KAMING REV 0 SHEET NO. 1/2
	X.±.012(0.30)	X'.±5'	CHECKED BY CHERRY	DATE 01/AUG/19	TITLE SD card connector (H=3.15mm)		
	X.X±.008(0.20)	.X'±2'	DRAWN BY KATE	DATE 01/AUG/19	THIS DRAWING CONTAINS INFORMATION THAT IS PROPRIETARY TO DONG GUAN LANG LUN (3K-KAMING) ELECTRONIC PRODUCTS CO., LTD. AND SHOULD NOT BE USED WITHOUT WRITTEN PERMISSION		

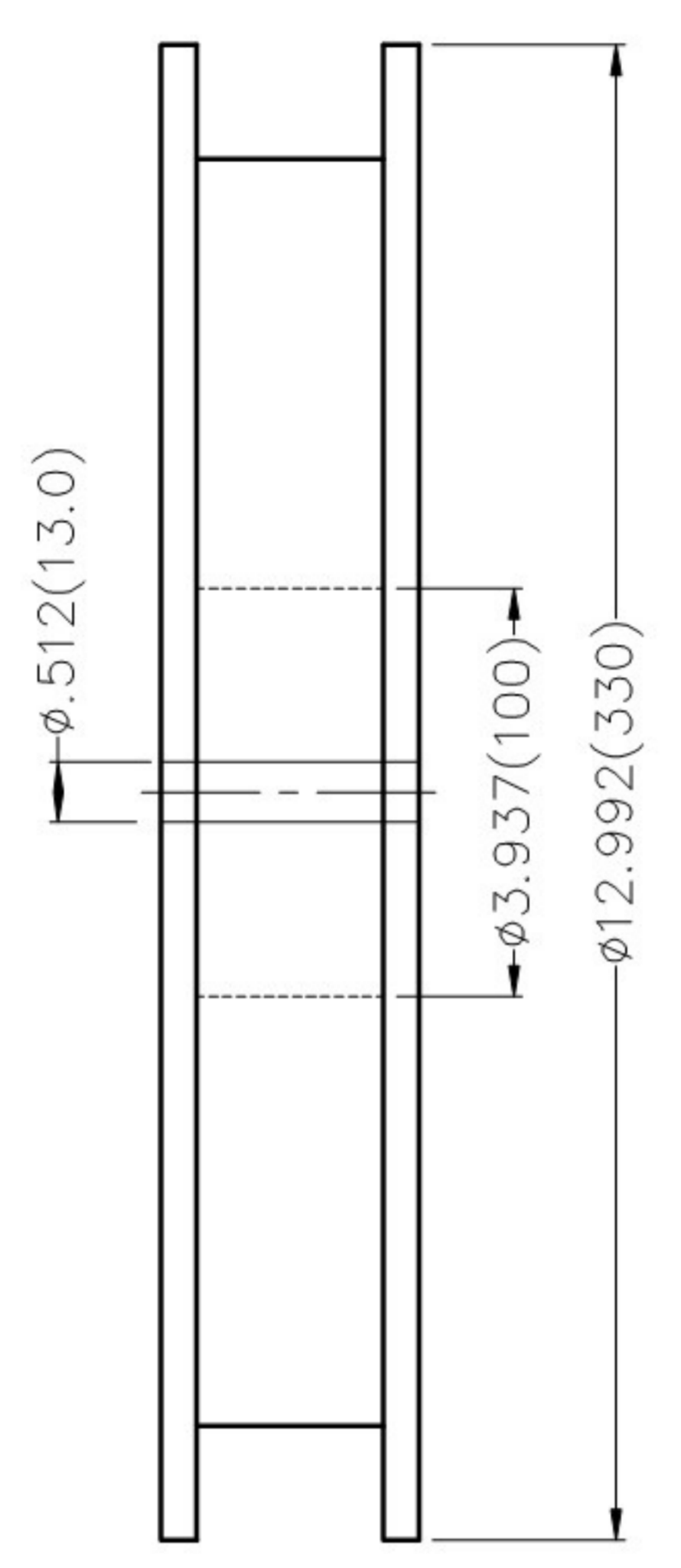
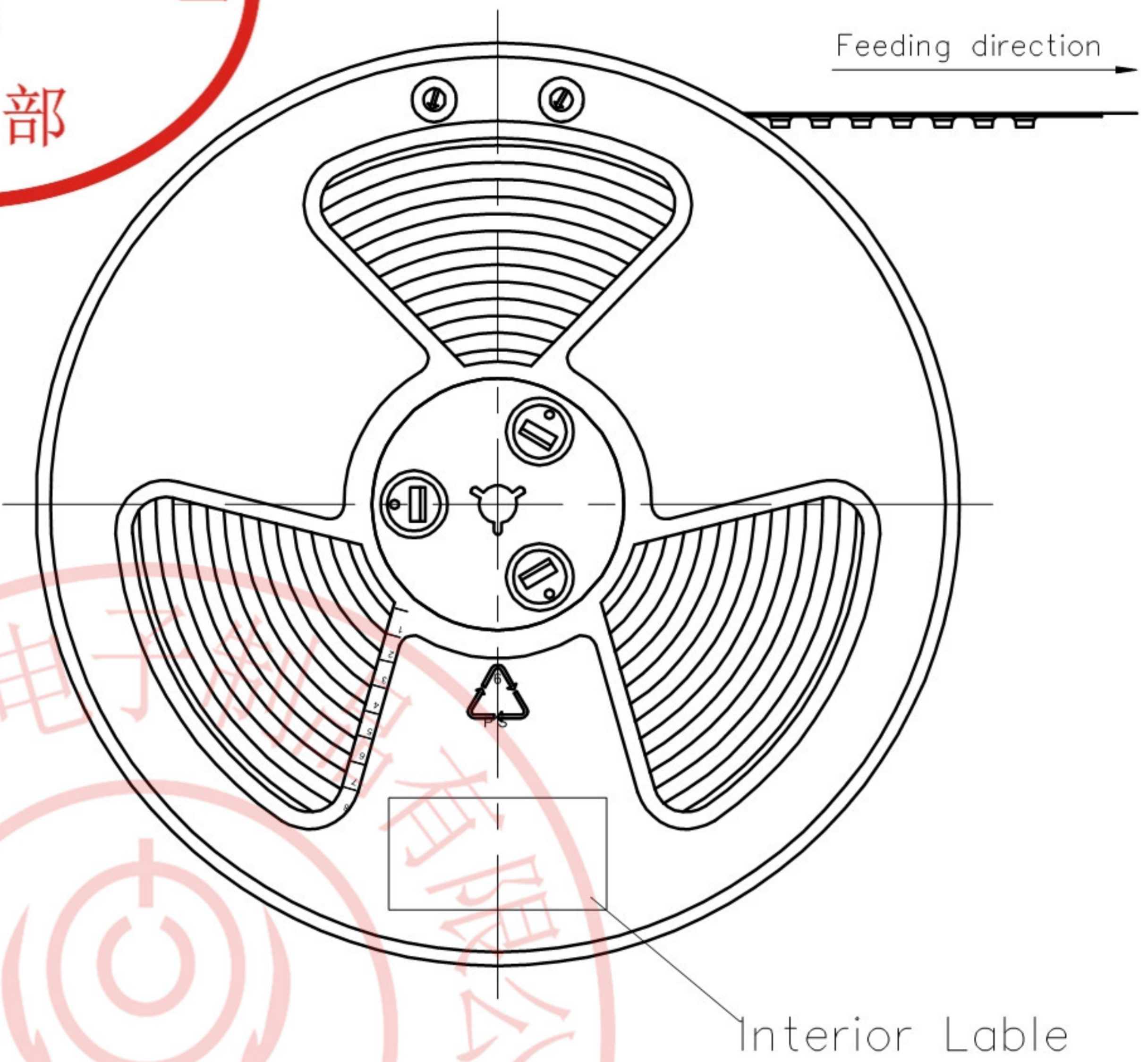

REV	LOCATIONS	DESCRIPTION	DATE	REVISER	APPD

- Note:
- 10 sprocket hole cumulative tolerance ± 0.2
 - Carrier camber is within 1.0mm in 100mm
 - Material: White Conductive polystyrene Alloy 100% recyclable
 - All dimensions meet EIA-481-3 requirements
 - Component load per 13" reel: 300 pcs

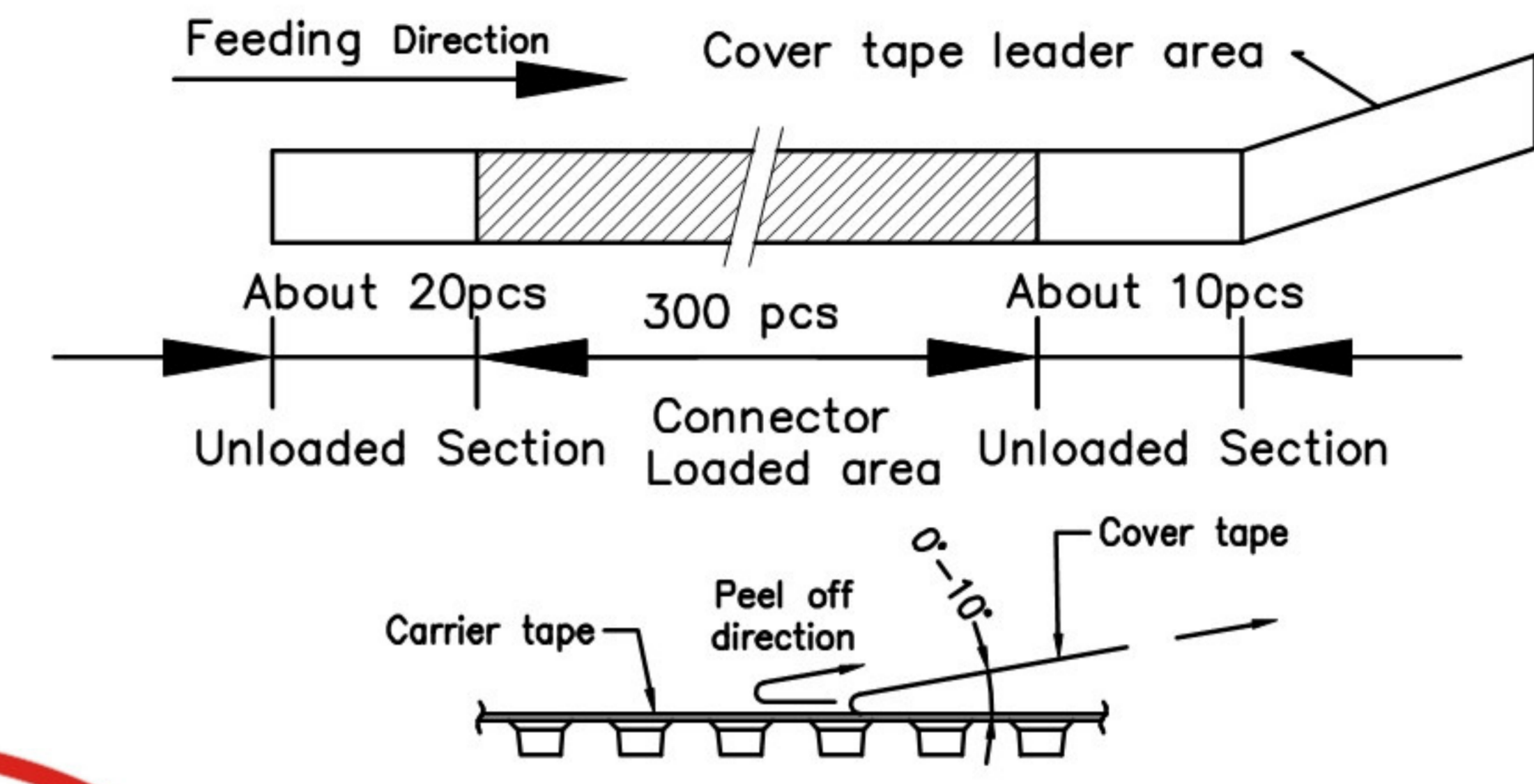

300 pcs/Reel

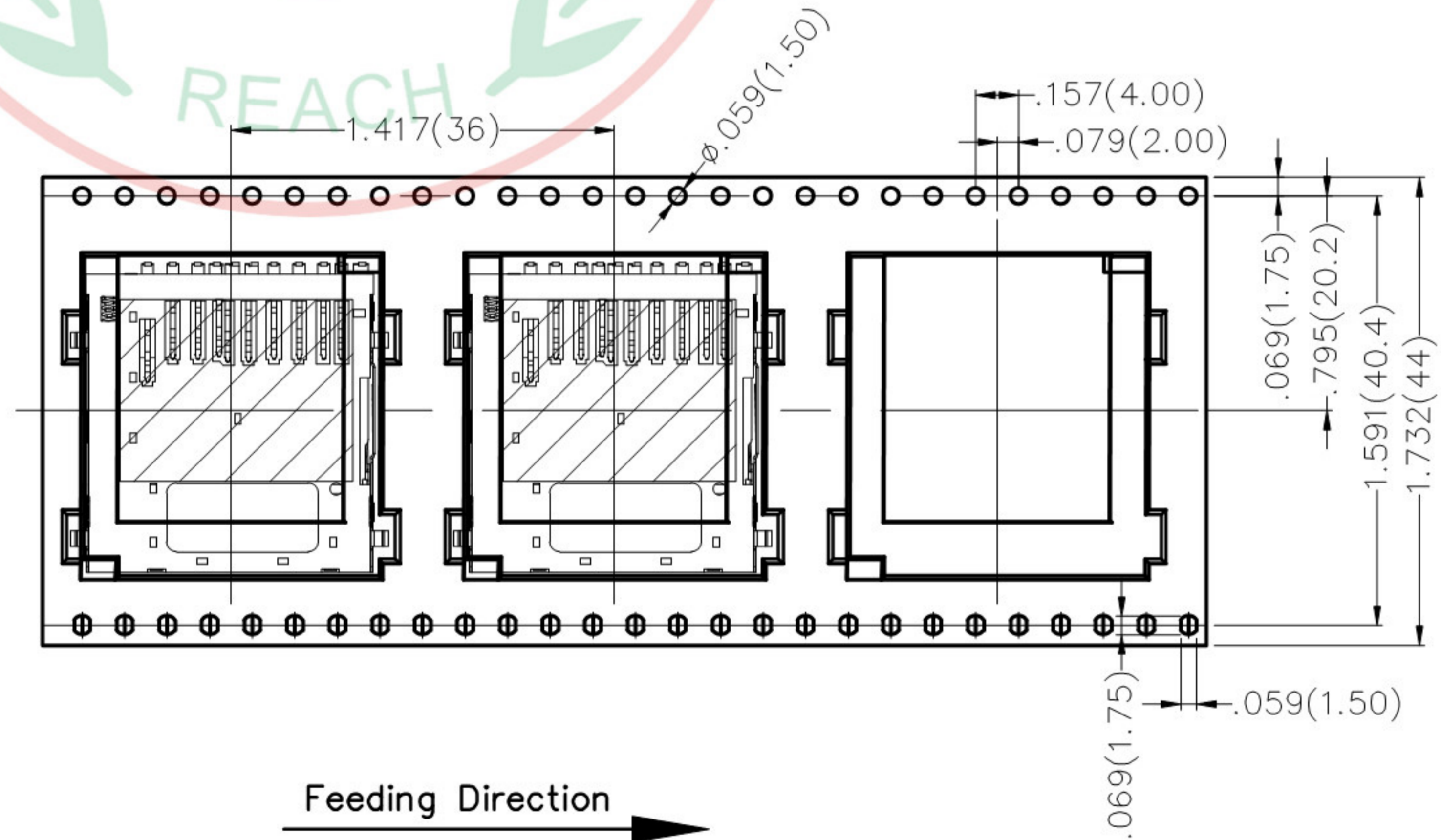
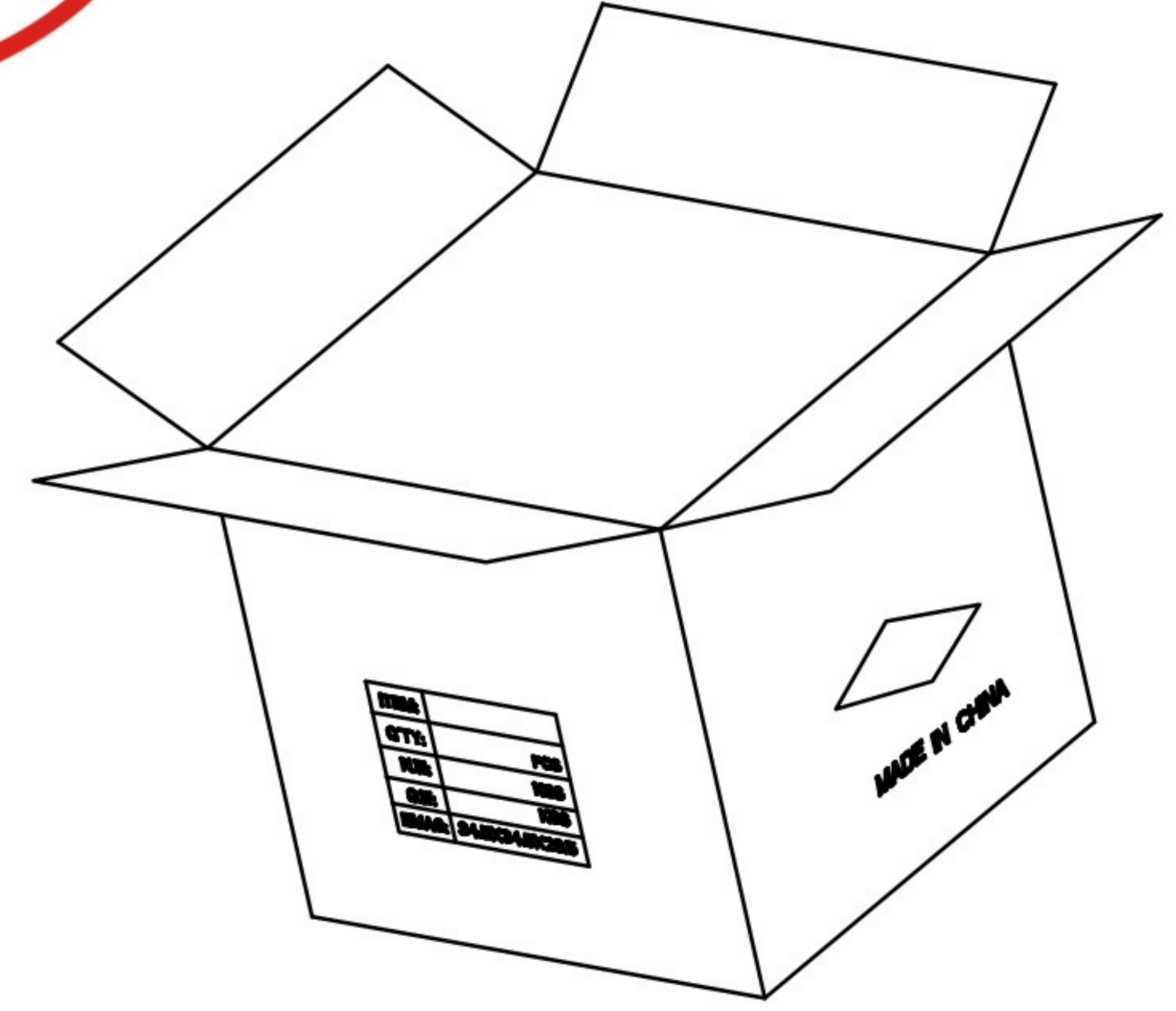
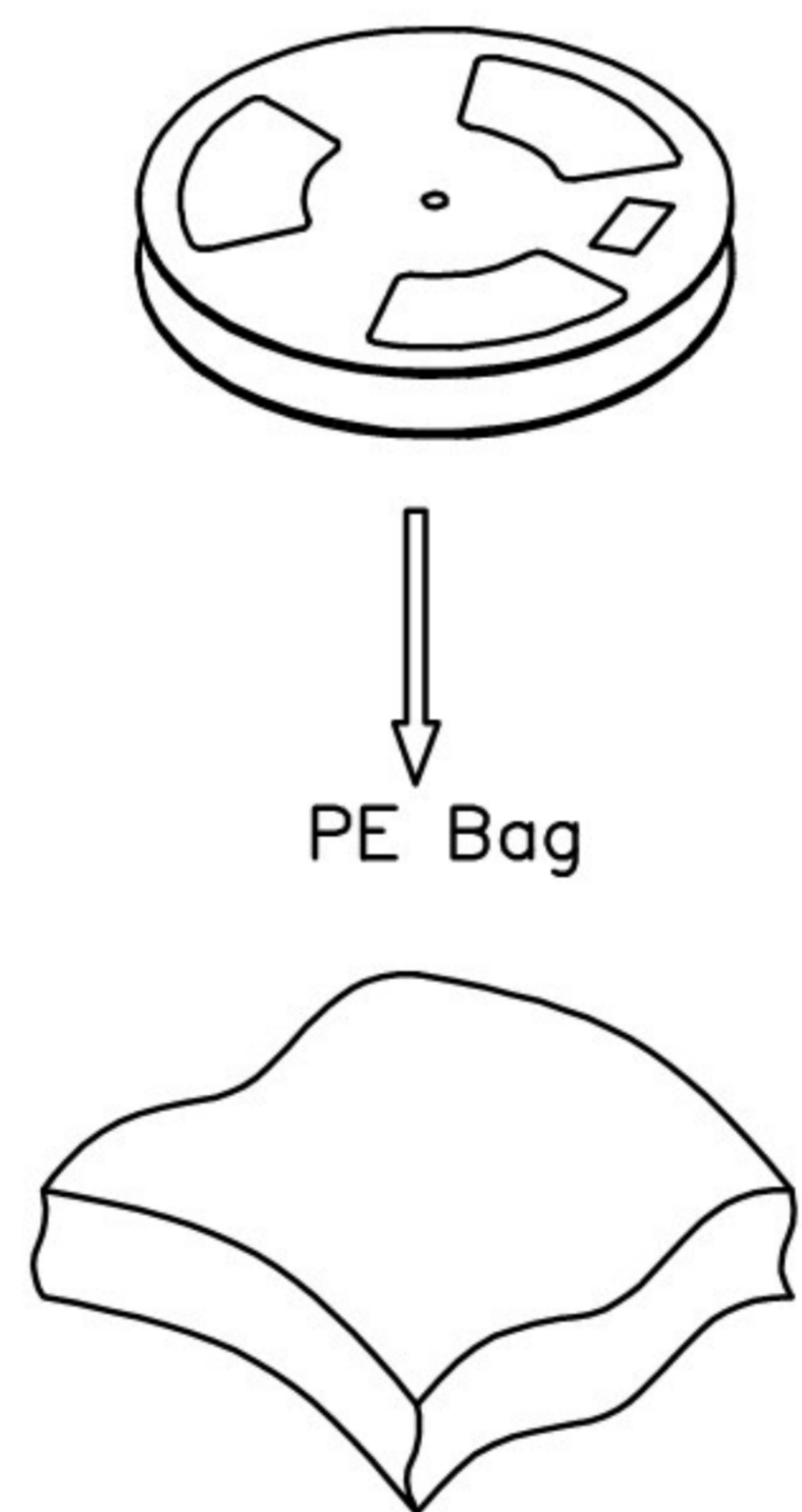

 THIRD ANGLE PROJECTION DESIGN UNITS Inch (metric) SCALE 5:1 SIZE A4	GENERAL TOLERANCES (UNLESS SPECIFIED)		APPROVE BY FRANK	DATE 01/AUG/19	PART NO. FCD133-7M	ITEM NO. FCD133	 3K-KAMING	
	X. \pm .012(0.30)	X. \pm 5'	CHECKED BY CHERRY	DATE 01/AUG/19	TITLE SD card connector (H=3.15mm)			REV 0
	X.XX \pm .008(0.20)	.X' \pm 2'	DRAWN BY KATE	DATE 01/AUG/19	THIS DRAWING CONTAINS INFORMATION THAT IS PROPRIETARY TO DONG GUAN LANG LUN (3K-KAMING) ELECTRONIC PRODUCTS CO., LTD. AND SHOULD NOT BE USED WITHOUT WRITTEN PERMISSION			
	X.XX \pm .006(0.15)	.XX' \pm 1'						
	X.XXX \pm .004(0.10)	.XXX' \pm 0.5'						