

REV	LOCATIONS	DESCRIPTION	DATE	REVISER	APPD
2		Update version	19/MAY/17	LXF	FRANK
3	△3	Add the "TXGA" logo	26/OCT/18	KATE	ANDY
4	△4	Structure change	09/MAY/20	KATE	CHERRY

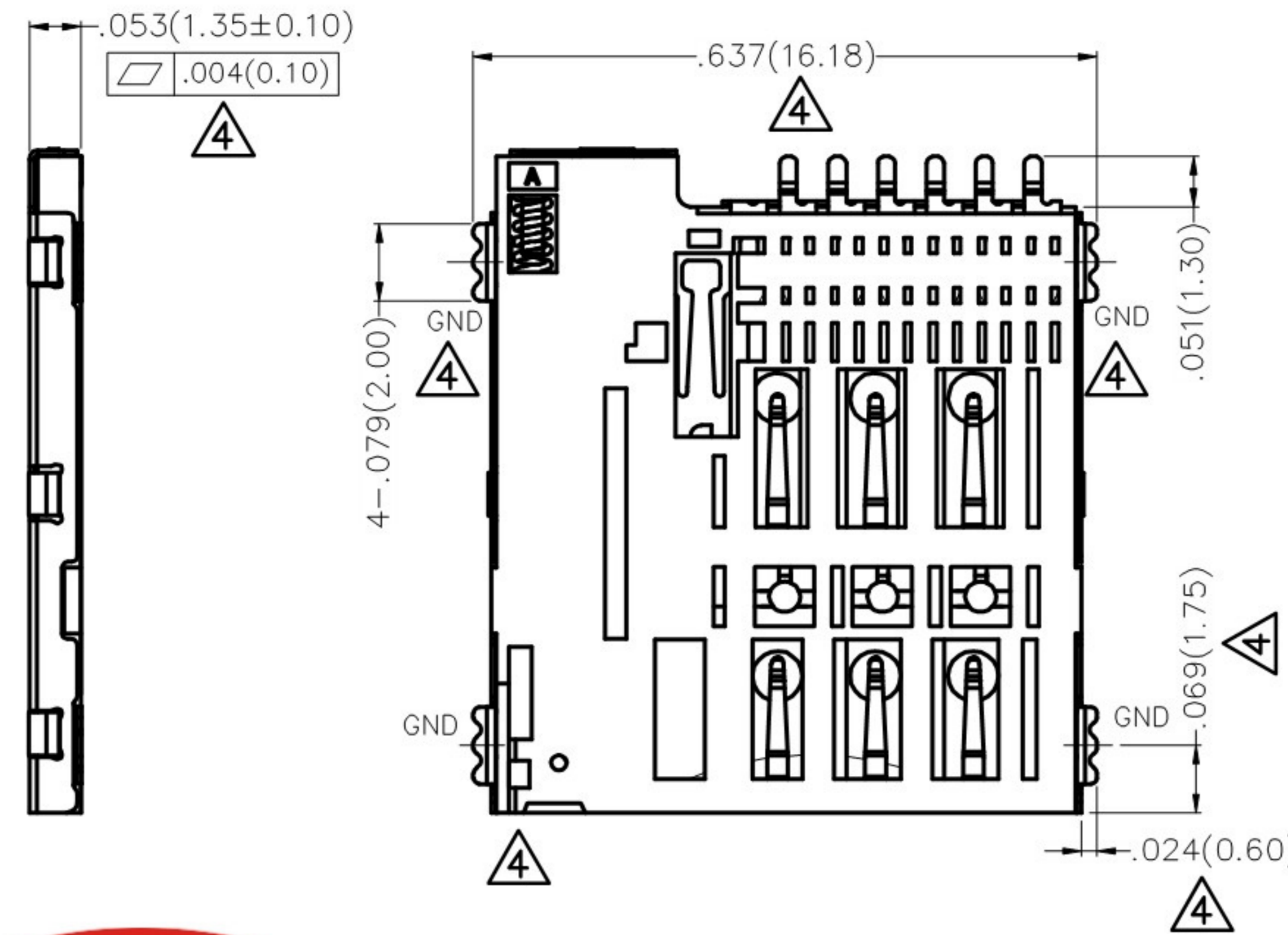
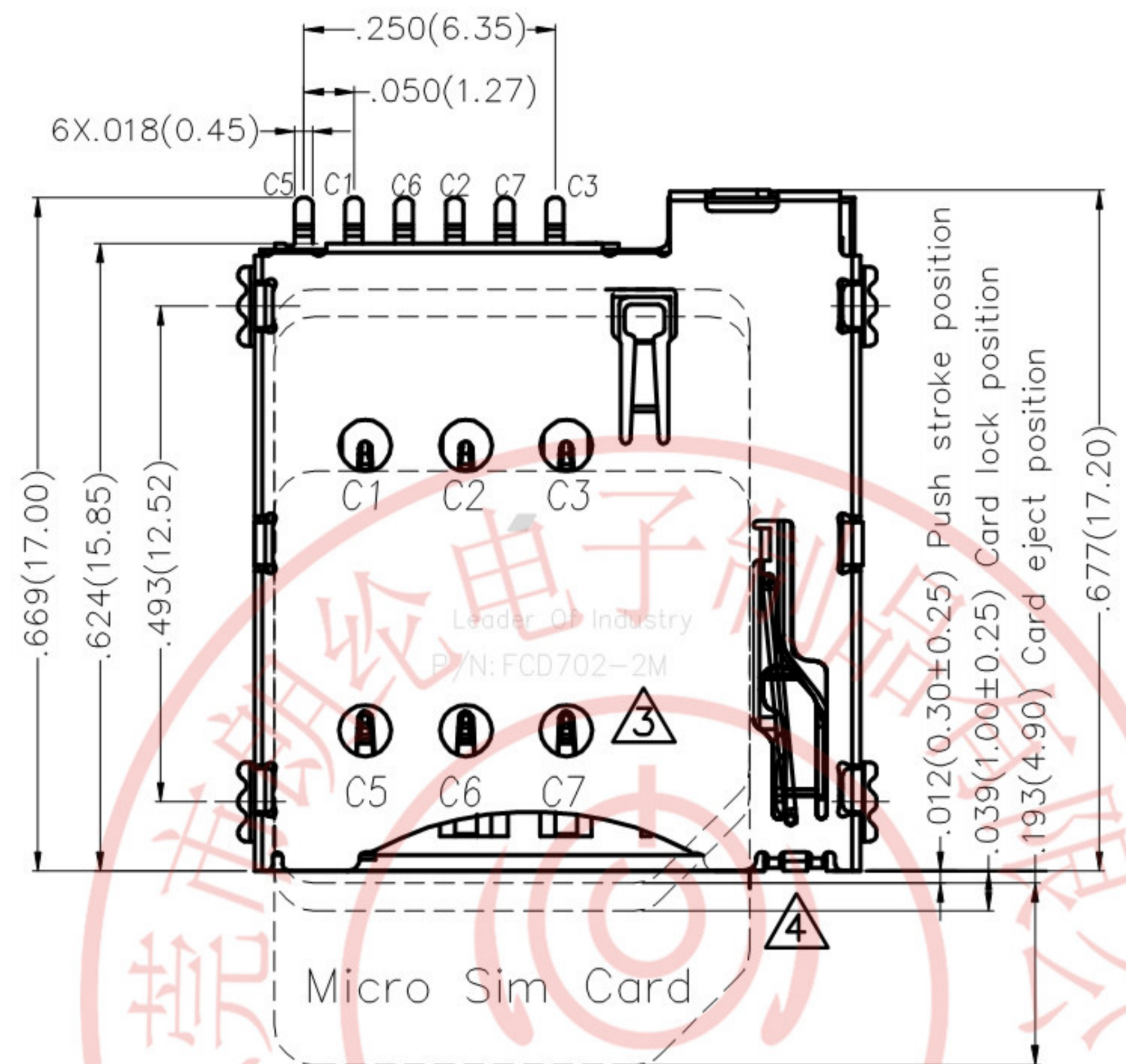

Electrical

Current Rating: 0.5A AC(rms)/DC
Voltage Rating: 50V AC(rms)/DC
Contact Resistance: 100 mΩ Max
Insulation Resistance: 1000 MΩ MIN
Withstanding Voltage: 500V AC r.m.s
Temperature Range-Operating: -25°C~+85°C
Durability: 5,000 Cycles

Material

Housing: Thermoplastic (UL 94V-0)
Contact Pin: Copper Alloy
Shell: Stainless

Plating

Contact Pin: Gold flash on contact, matte tin on tail
Shell: Nickel plated, gold flash on solder tail

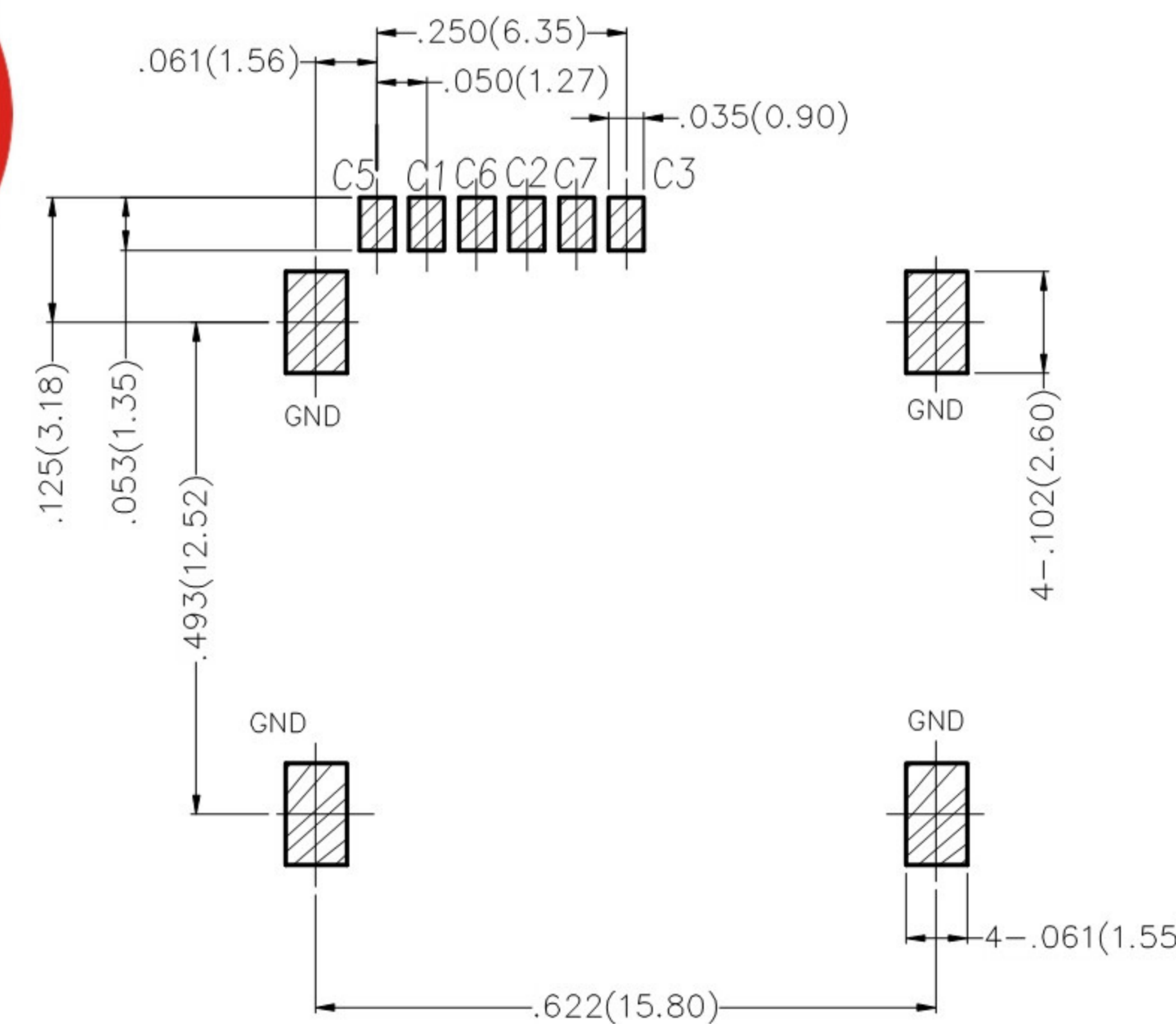
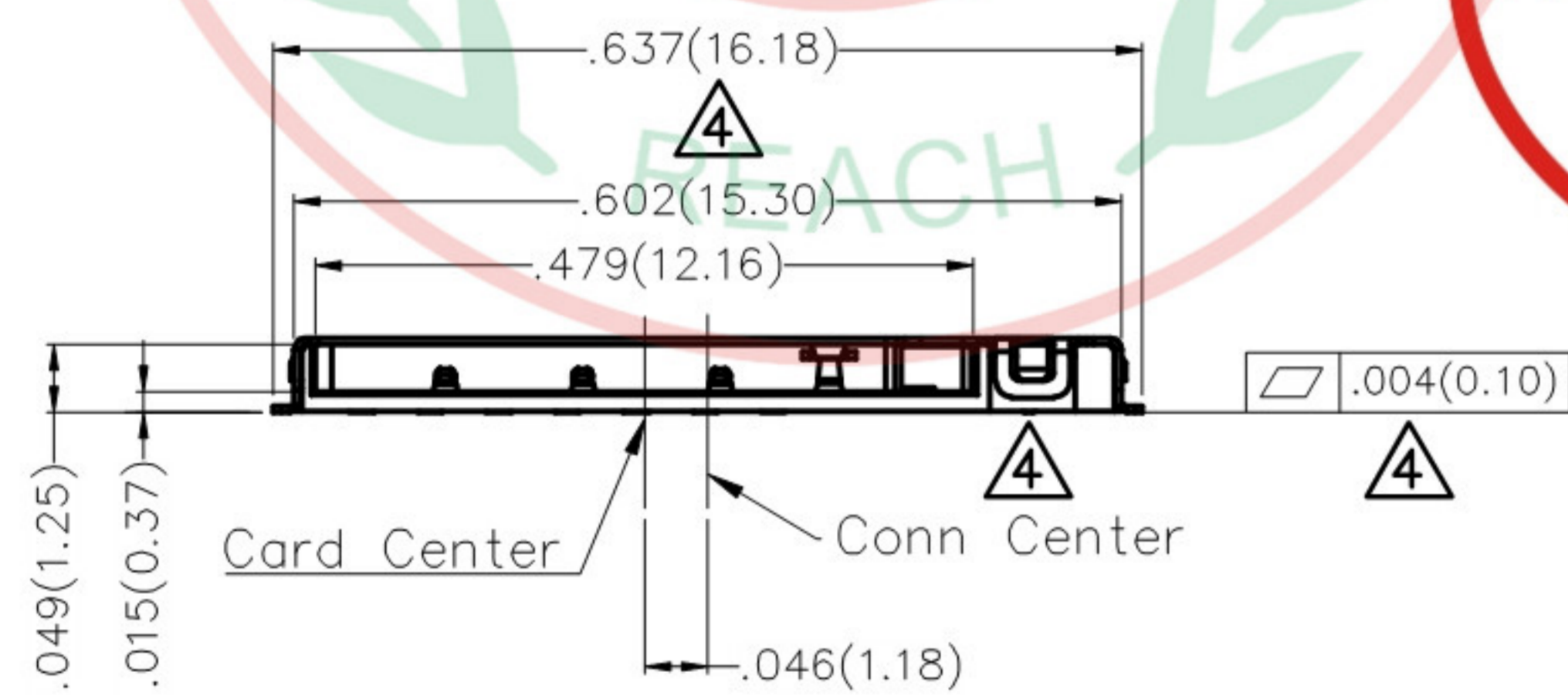

Recommended P.C.Board Layout
GENERAL TOLERANCES: ±0.05mm

PIN NO.	PIN NAME
C1	Supply Voltage Vcc
C2	Rest(RST)
C3	Clock(CLK)
C4	N/A
C5	Ground(GND)
C6	Programming Voltage Vpp
C7	I/O

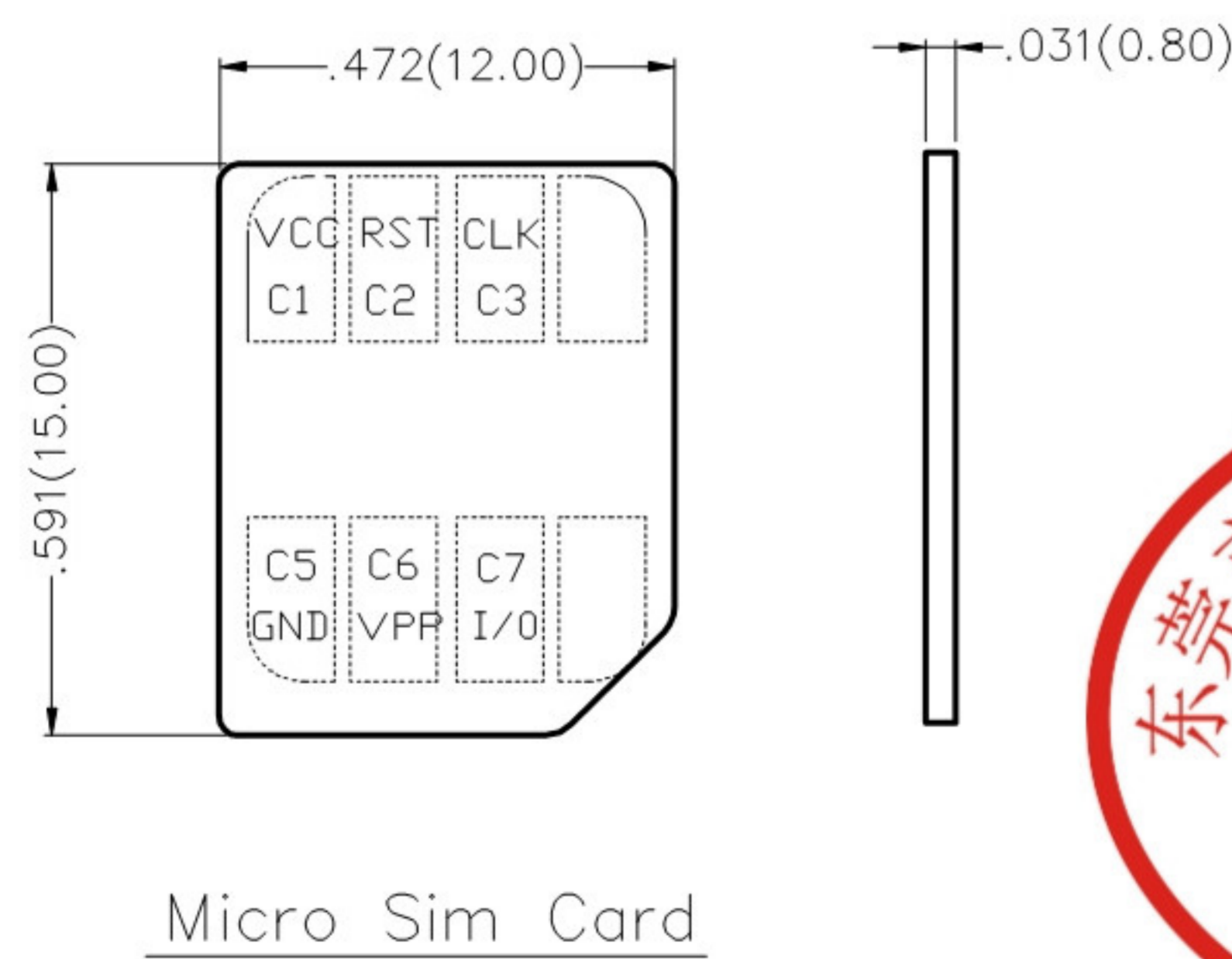

 THIRD ANGLE PROJECTION	GENERAL TOLERANCES (UNLESS SPECIFIED)		APPROVE BY	DATE	PART NO.	ITEM NO.	 3K-KAMING®
	X.±.012(0.30)	X.±5'	FRANK	16/MAY/17	FCD702-2M	FCD702	
	X.X±.008(0.20)	.X'±2'	CHECKED BY	DATE	TITLE		
	X.XX±.006(0.15)	.XX'±1'	JACOB	16/MAY/17	SIM card connector(H:1.35mm) (Push to Push)		
SCALE	SIZE	X.XXX±.004(0.10)	.XXX'±0.5'	DRAWN BY	DATE	THIS DRAWING CONTAINS INFORMATION THAT IS PROPRIETARY TO DONG GUAN LANG LUN(3K-KAMING) ELECTRONIC PRODUCTS CO.,LTD. AND SHOULD NOT BE USED WITHOUT WRITTEN PERMISSION	
5:1	A4			LXF	16/MAY/17	REV 4	SHEET NO. 1/2

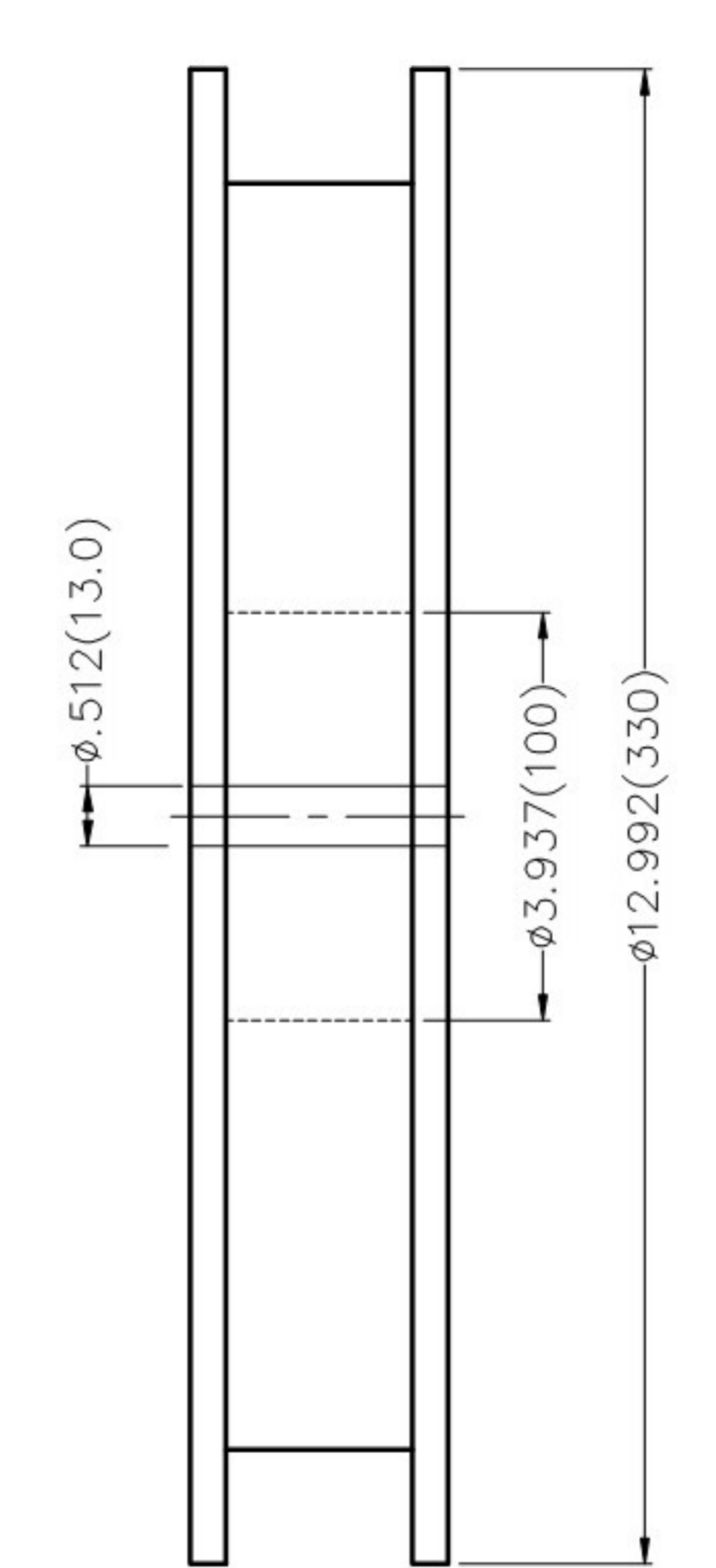
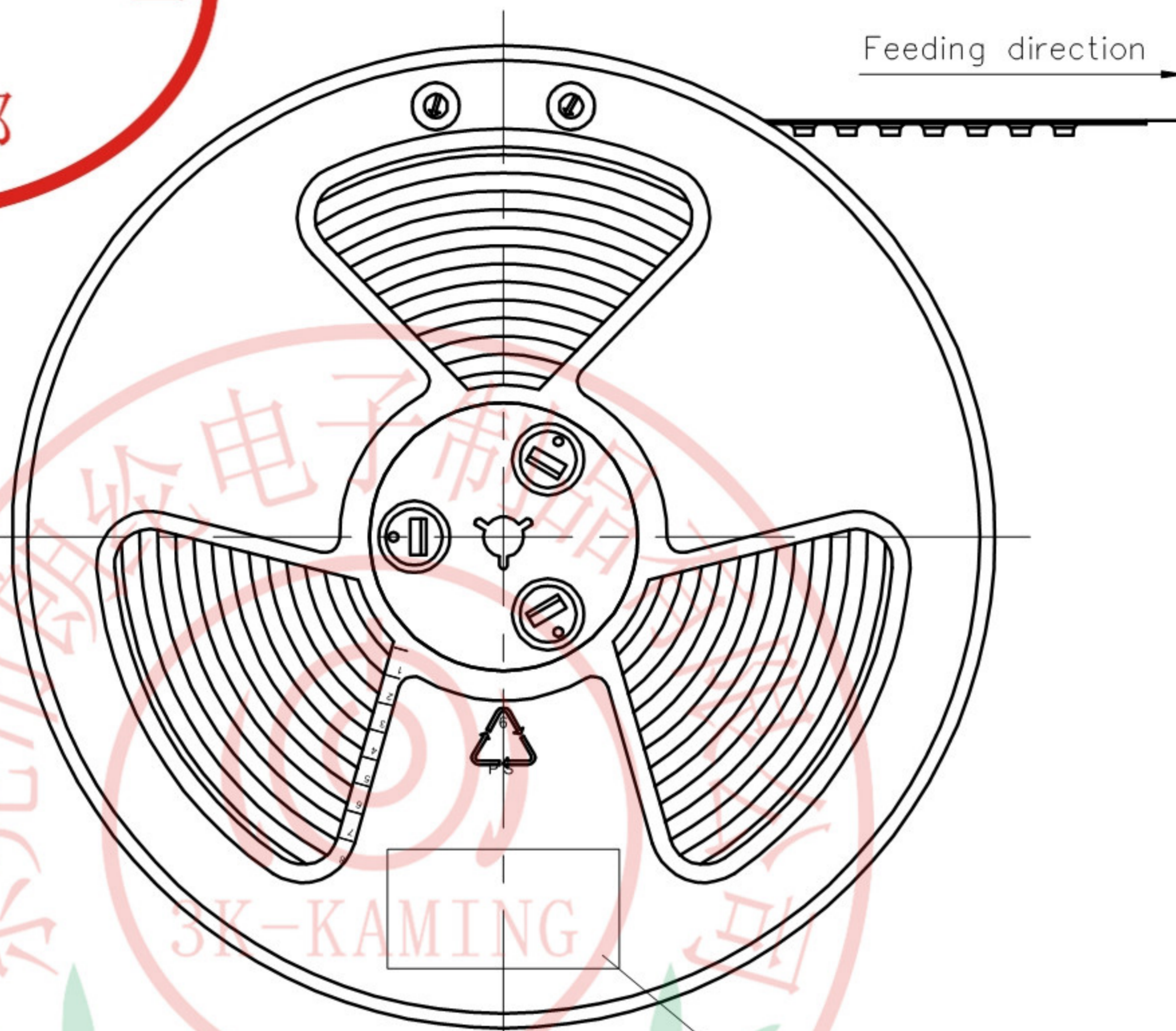

REV	LOCATIONS	DESCRIPTION	DATE	REVISER	APPD

- Note:
- 10 sprocket hole cumulative tolerance ± 0.2
 - Carrier camber is within 1.0mm in 100mm
 - Material: White Conductive polystyrene Alloy 100% recyclable
 - All dimensions meet EIA-481-3 requirements
 - Component load per 13" reel: 1,000 pcs

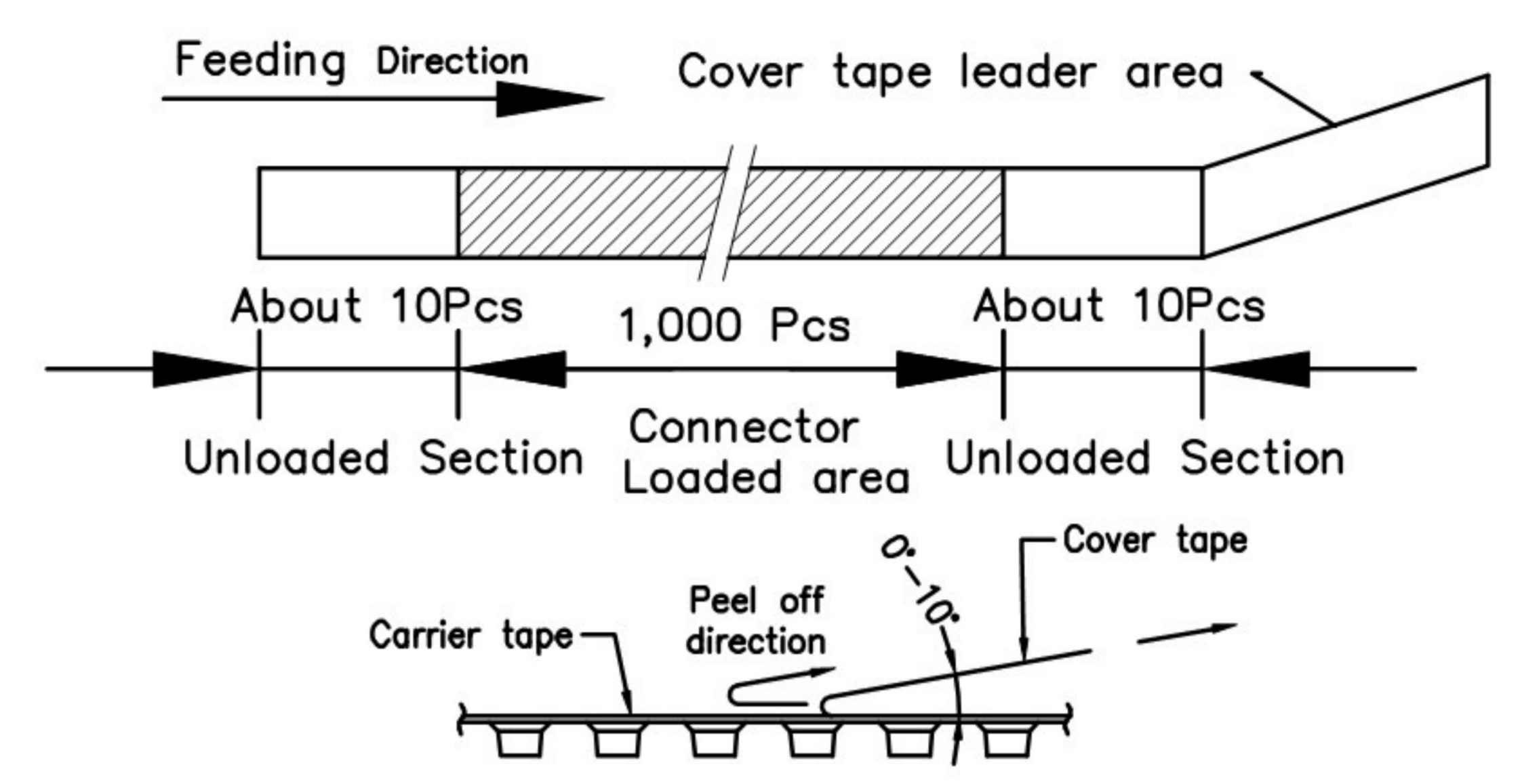

Interior Lable

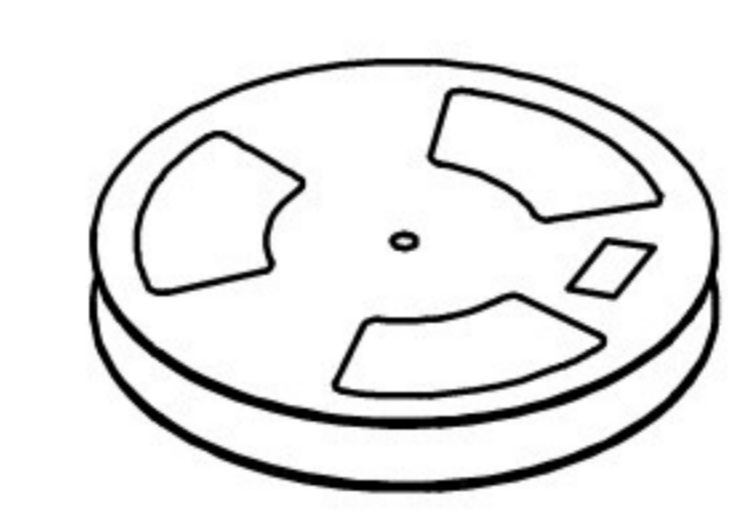
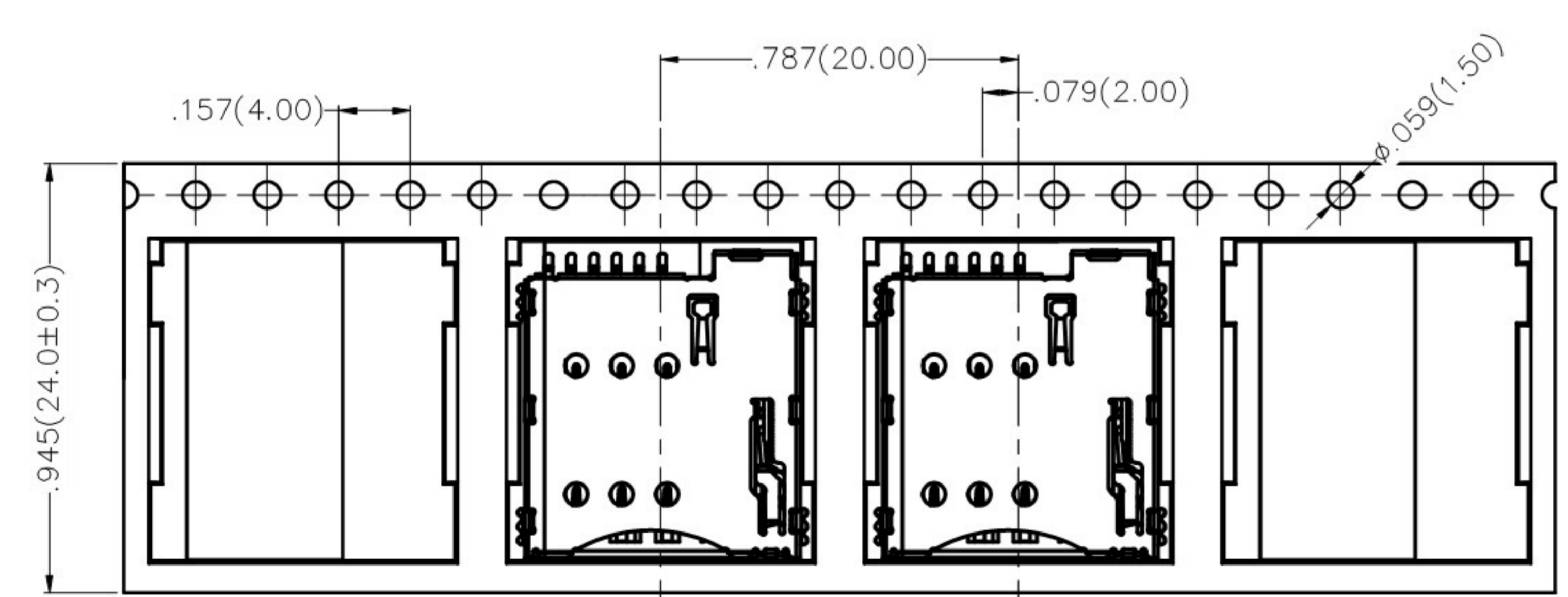

1,000 pcs/Reel

PE Bag

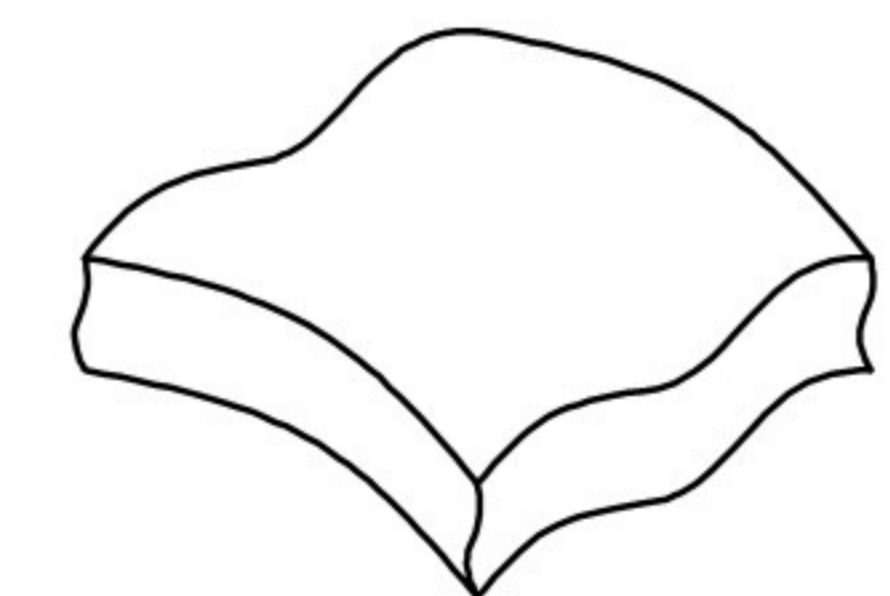

Drying agent/pcs

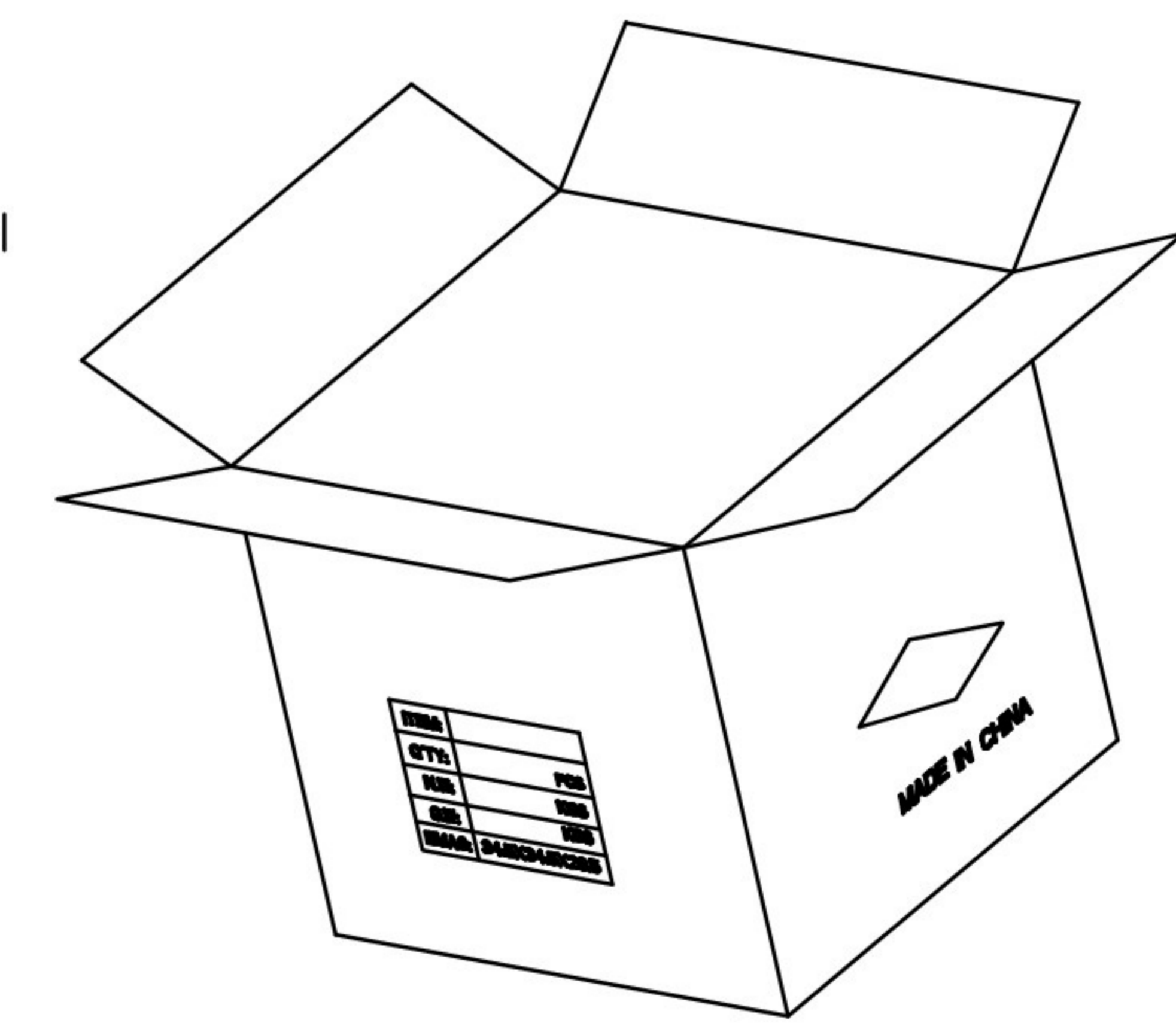

Feeding Direction



 THIRD ANGLE PROJECTION	GENERAL TOLERANCES (UNLESS SPECIFIED)		APPROVE BY	DATE	PART NO.	ITEM NO.	 3K-KAMING
	X.±.012(0.30)	X.±5'	FRANK	28/AUG/13	FCD702-2M	FCD702	
DESIGN UNITS Inch (metric)	X.X±.008(0.20)	.X'±2'	CHECKED BY	DATE	TITLE		REV 4
SCALE	X.XX±.006(0.15)	.XX'±1'	CHERRY	28/AUG/13	SIM card connector(H:1.35mm) (Push to Push)		
5:1	X.XXX±.004(0.10)	.XXX'±0.5'	DRAWN BY	DATE	THIS DRAWING CONTAINS INFORMATION THAT IS PROPRIETARY TO DONG GUAN LANG LUN(3K-KAMING) ELECTRONIC PRODUCTS CO., LTD. AND SHOULD NOT BE USED WITHOUT WRITTEN PERMISSION		
SIZE A4			JACOB	28/AUG/13			