

ALLOWANCE	
UNDER 3	±0.1
3 TO 6	±0.15
6 TO 15	±0.2
15 TO 50	±0.25
50 OVER	±0.3

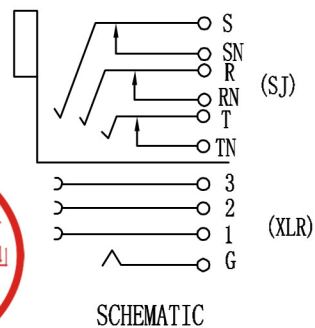
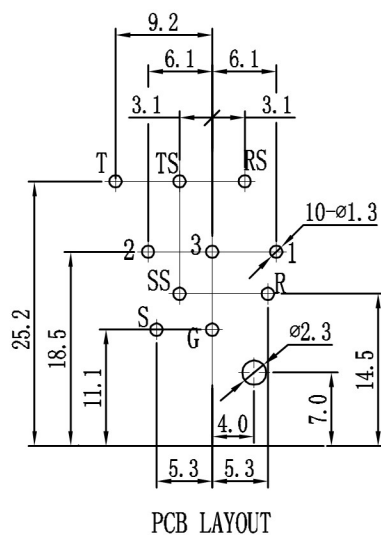
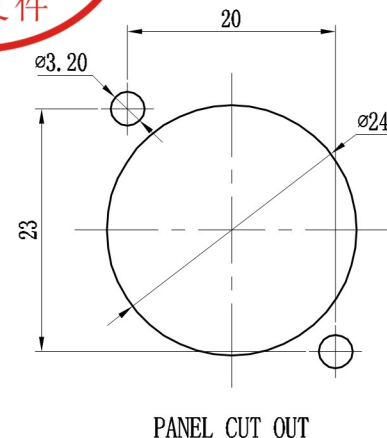
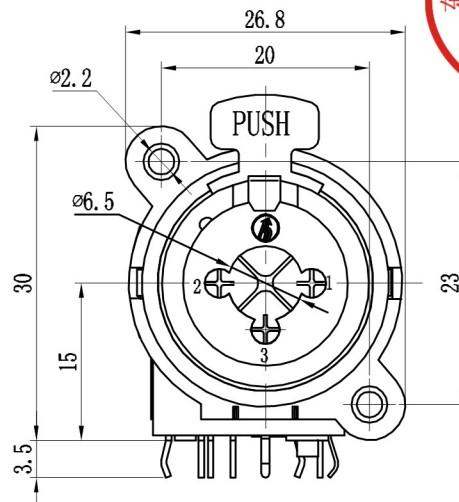
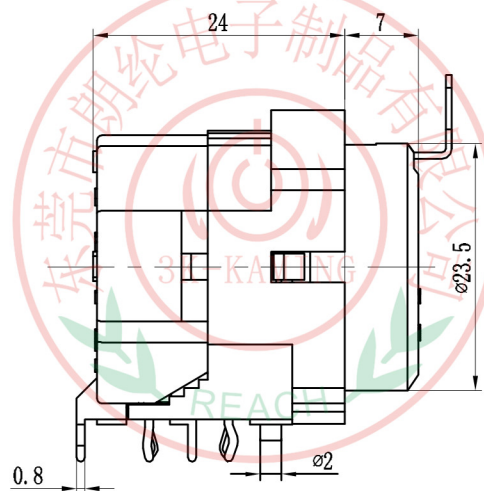

Specifications:
 Rating :AC 50V, 3A.
 Force:5-40N.
 Contact resistance:
 Less than30mΩ.
 Insulation resistance:
 Over 1GΩ on DC 500V measured.
 Voltage withstand :
 AC 1000V, For 1 minute.

MODEL NO: SPC-16A	ALLOWANCE:	DRAWN BY:
TYPE: XLR CABLE CONNECTORS	UNIT: mm	CHECKED BY:
MATERIAL NO:	SCALE:	APPROVED BY:
PROJECTION		东莞市朗纶电子制品有限公司 Dongguan langlun electronic products Co., Ltd