

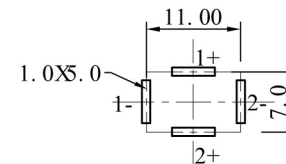

ALLOWANCE	
UNDER 3	± 0.1
3 TO 6	± 0.15
6 TO 15	± 0.2
15 TO 50	± 0.25
50 OVER	± 0.3

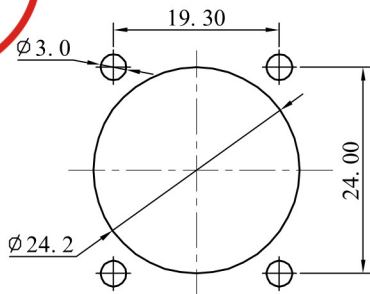
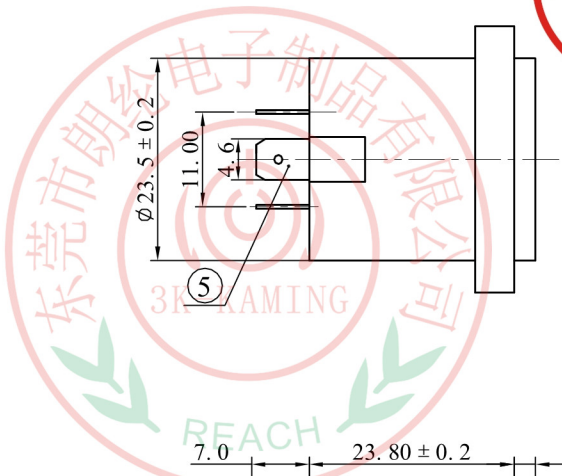

PANEL CUT OUT

PCB

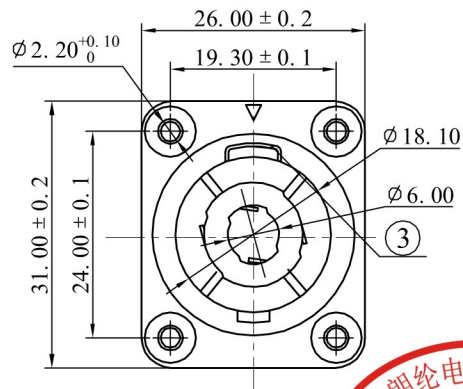
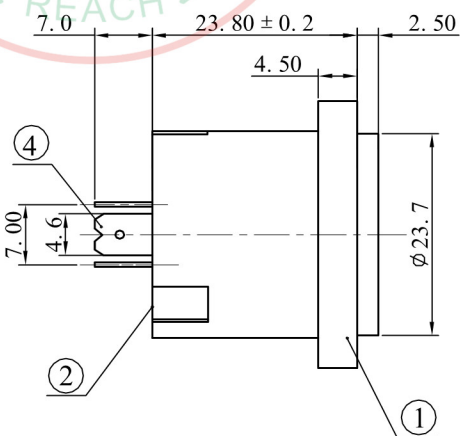

Specifications:
 Rating :DC 250V,20A.
 Force:5~40N.
 Contact resistance:
 Less than30m Ω.
 Insulation resistance:
 Over 100M Ω on DC 500V
 measured.
 Voltage withstand :
 AC 500V,For 1 minute.



5	TERMINAL-B	BRONZE t=0.4	2	Ag PLATED
4	TERMINAL-A	BRONZE t=0.4	2	Ag PLATED
3	TERMINAL-E	STEEL	1	
2	COVER	PA66	1	BLACK
1	HOUSE	PA66	1	BLACK
NQ	PART NAME	MATERIAL	QTY	FINISHING

MODEL NO :SPE-02A	ALLOWANCE:	DRAWN BY:
TYPE: SP SOCKET	UNIT: mm	CHECKED BY:
MATERIAL NO :	SCALE:	APPROVED BY:
PROJECTION		
	东莞市朗纶电子制品有限公司 Dongguan langlun electronic products Co., Ltd	