

ALLOWANCE	
UNDER 3	±0.1
3 TO 6	+0.15
6 TO 15	+0.2
15 TO 50	+0.25
50 OVER	+0.3

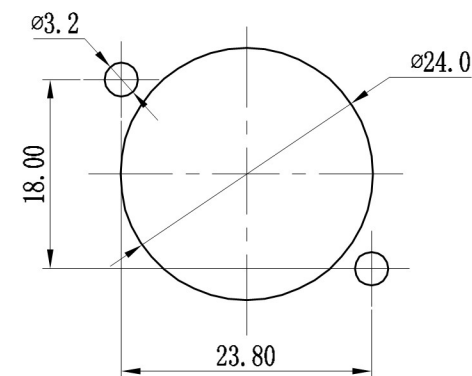

PANEL CUT OUT

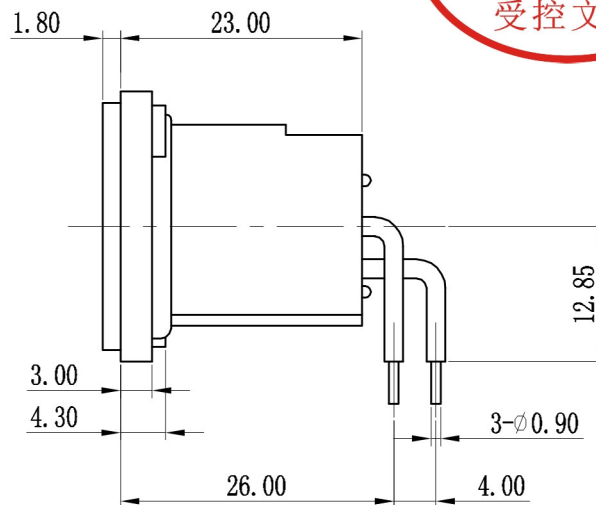
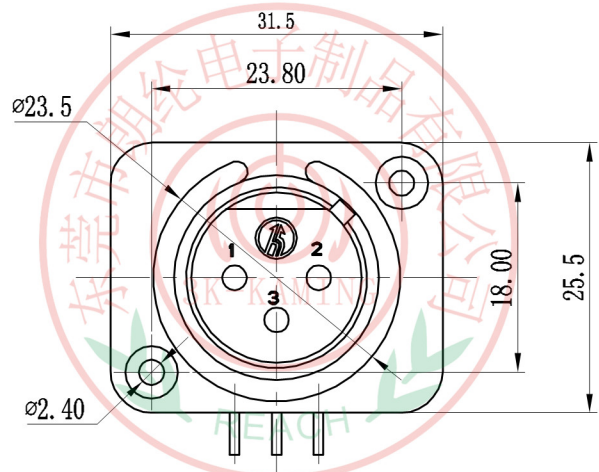
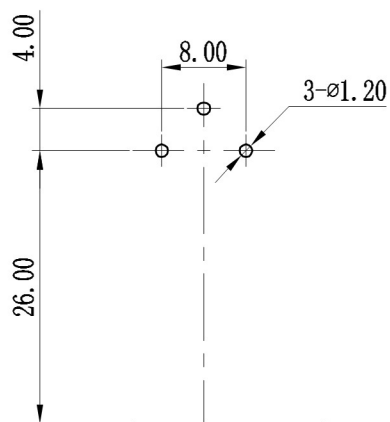

PCB LAYOUT



Specifications:  
 Rating :AC 50V, 3A.  
 Force:5-40N.  
 Contact resistance:  
 Less than30mΩ.  
 Insulation resistance:  
 Over 1GΩ on DC 500V measured.  
 Voltage withstand :  
 AC 1000V, For 1 minute.

MODEL NO: SPM-19	ALLOWANCE:	DRAWN BY:
TYPE: SP SOCKET	UNIT: mm	CHECKED BY:
MATERIAL NO:	SCALE:	APPROVED BY:
PROJECTION		