

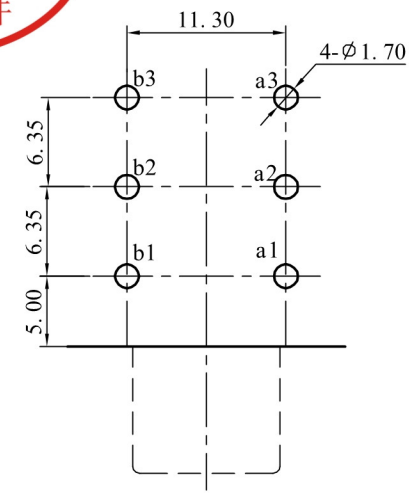

ALLOWANCE	
UNDER 3	± 0.1
3 TO 6	± 0.15
6 TO 15	± 0.2
15 TO 50	± 0.25
50 OVER	± 0.3

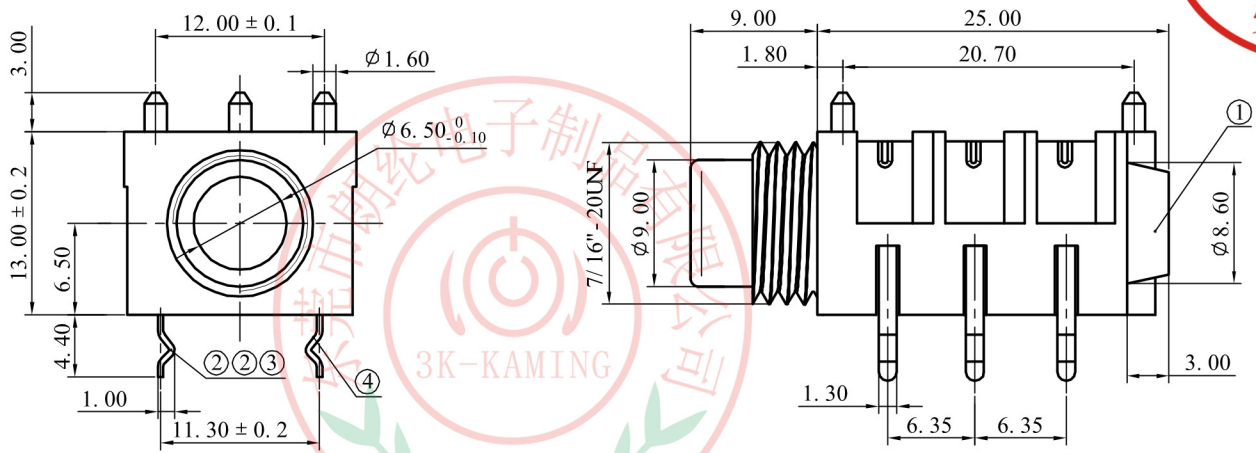

PCB LAYOUT

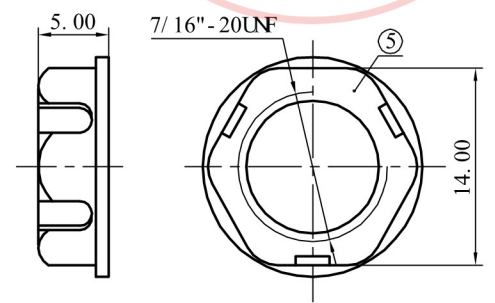

NUT

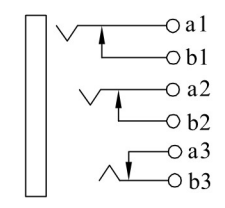

SCHEMATIC

5	NUT	PA66	1	BLACK
4	TERMINAL-C	BRONZE t=0.4	3	Ag PLATED
3	TERMINAL-B	BRASS t=0.4	1	Ag PLATED
2	TERMINAL-A	BRASS t=0.4	2	Ag PLATED
1	HOUSE	PA66	1	BLACK
NO.	PART NAME	MATERIAL	QTY	FINISHING

MODEL NO : SI6338B-6P	ALLOWANCE:	DRAWN BY:
TYPE : 6.35 PHONE JACK	UNIT: mm	CHECKED BY:
MATERIAL NO :	SCALE:	APPROVED BY:
PROJECTION	东莞市朗纶电子制品有限公司 Dongguan langlun electronic products Co., Ltd	