

外型图 (Outline Drawing)

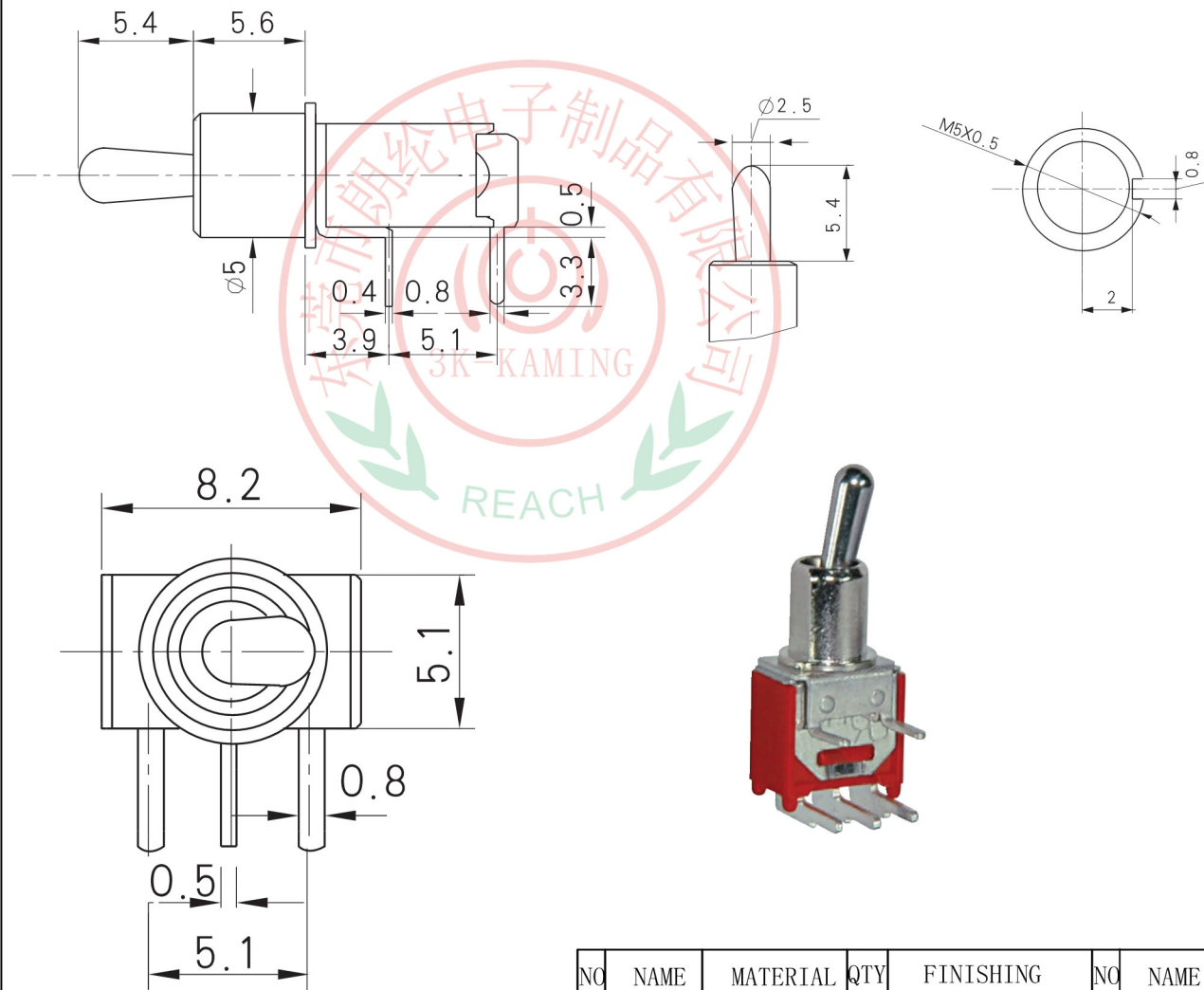

安规认证 (Safety Certification)



自由公差		
区分	类别	公差
0	<0.5	±0.10
0.50	<5	±0.15
5.0	<10	±0.20
10.0	<20	±0.30
20.0	<50	±0.40
未标注R角		R0.2
未标注角度公差		±1°

电路图 (Circuitry)

SMS-102-C3 ON-ON
 SMS-103-C3 ON-OFF-ON
 SPDT 3P



技术特性 (Specification)

- 技术特性 Specification
- 规格 Rating: 3A 125V AC; 1.5A 250V AC
 - 接触电阻 Contact R: 20mΩ Max
 - 绝缘电阻 Insulation R: 500V DC 1000MΩ Min
 - 耐电压 Dielectric strength: 1000V AC, 1 Minute
 - 操作温度 Operating temperature: -20°C ~ +65°C
 - 电气寿命 Electrical life: 20,000 Cycles

NO	NAME	MATERIAL	QTY	FINISHING	NO	NAME	MATERIAL	QTY	FINISHING	APVD	DATE			
1	手柄	黄铜	1	镀铬	7	动触片	H65	1	镀银	SPECIFICATION NO.	2020-03-04			
2	轴套	黄铜	1	镀铬	8	端子	H65	3	镀银	TITLE	TOGGLE SWITCH			
3	铁盖	SUS	1	本色	9	底座	PPA	1	红色	PART NO.	SMS-10X-C3			
4	弹簧	碳钢	1	黑色	10	插脚	SPCC	1	镀银	MATERIAL NO.	SM00066ZNR			
5	摆杆	SPCC	1	镀镍	东莞市朗纶电子制品有限公司 Dongguan langlun electronic products Co., Ltd					SCALE	1:1		UNIT:	mm
6	滑块	PA46	1	黑色						CKD			DWN	黄泳何