

外型图 (Outline Drawing)

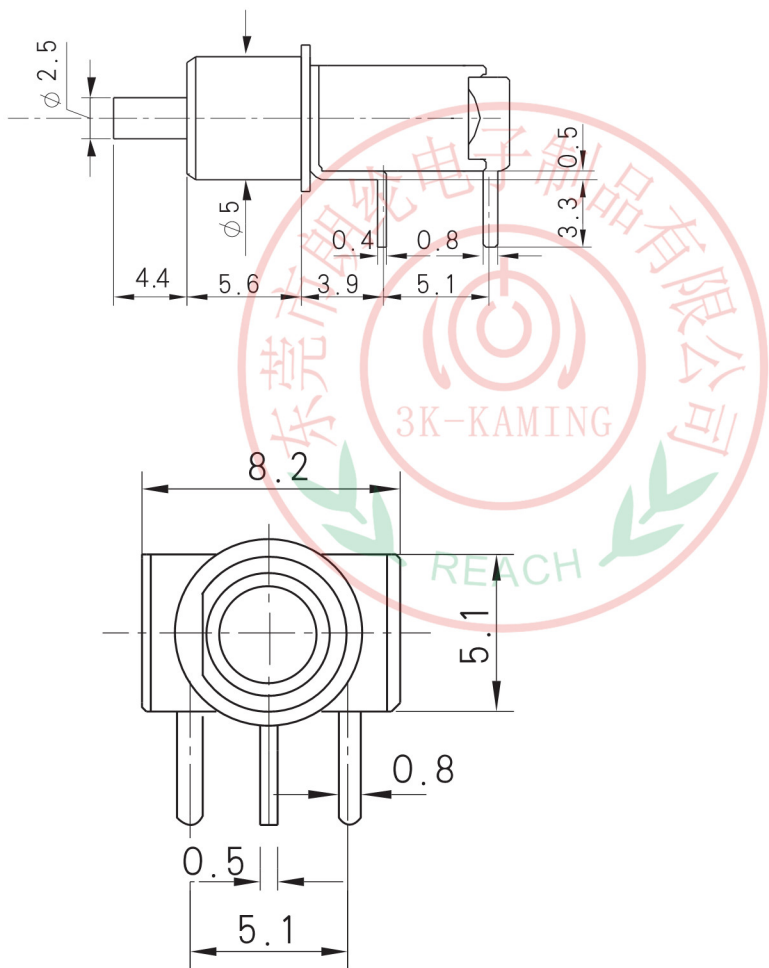

安规认证 (Safety Certification)



自由公差		
区分	类别	公差
0	<0.5	±0.10
0.50	<5	±0.15
5.0	<10	±0.20
10.0	<20	±0.30
20.0	<50	±0.40
未标注R角		R0.2
未标注角度公差		±1°

电路图 (Circuitry)

PUSH ON-(ON)
Open & Close Terminal
SPDT 3P



技术特性 (Specification)

- | | |
|---------|--|
| 技术特性 | Specification |
| 1. 规格 | Contact rating:1.5A 250V AC;3A 125V AC |
| 2. 接触电阻 | Contact R:20mΩ Max |
| 3. 绝缘电阻 | Insulation R: 500V DC 1000MΩ Min |
| 4. 耐电压 | Dielectric strength:1000V AC,1 Minute |
| 5. 操作温度 | Operating temperature:-20℃~+65℃ |
| 6. 电气寿命 | Electrical life:20,000 C cles |



NO	NAME	MATERIAL	QTY	FINISHING	NO	NAME	MATERIAL	QTY	FINISHING	APVD	DATE	2020-03-04		
1	手柄	黄铜	1	镀铬	7	动触片	H65	1	镀银	SPECIFICATION NO.				
2	轴套	黄铜	1	镀铬	8	端子	H65	3	镀银	TITLE	TOGGLE SWITCH			
3	铁盖	SUS	1	本色	9	基座	PPA	1	红色	PART NO.	SMPS-1CO-A3			
4	弹簧	碳钢	1	黑色	10	插脚	SPCC	1	镀银	MATERIAL NO.	SM00066ZNR			
5	摆杆	SPCC	1	镀镍	 东莞市朗纶电子制品有限公司 Dongguan langlun electronic products Co., Ltd					SCALE	1:1		UNIT:	mm
6	滑块	PA46	1	黑色						CKD		DWN	黄泳何	