

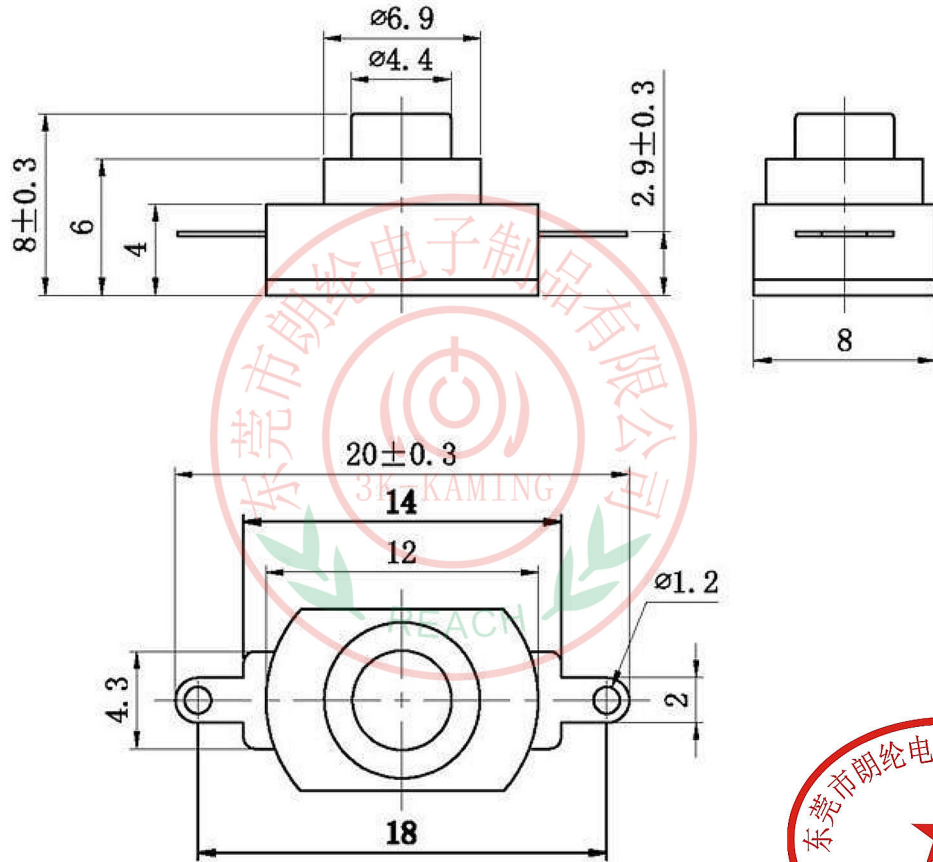

RoHS
Compliant
2002/95/EC

REV.	ECN.	NO.	APPD.

DIMENSIONS



ELECTRO-MECHANICAL CHARACTERISTICS

Refer to additional specifications

1	额定负荷Rated load	AC 250V 1A
2	接触电阻Contact resistance	≤100mΩ
3	绝缘电阻Insulation resistance	≥100MΩ
4	耐压Withstand Voltage	AC 500V (50HZ) /1min
5	电器寿命Life	≥20000
6	动作力度Strength of action	800±50gf
7	环境温度The environment temperature	-15~75℃
8	相对湿度Relative humidity	≤95% (40℃)
9		
10		
11		



NO	配件Accessories	材料名称Material	产地Place of origin	备注Note	WITHIN 1.5mm: ±0.1mm	UNITS mm	 东莞市朗纶电子制品有限公司 Dongguan langlun electronic products Co., Ltd	
1	上盖/底座Topcover/base	PA66	进口/国产Imports / domestic	黑或白Black or white	OVER 1.5mm: ±0.2mm	MAT'L		
2	按钮/内件Button/interior	POM	进口/国产Imports / domestic	黑或白Black or white		SEE NOTE		
3	端子/拉伸件Terminals/stretchers	黄铜Brass	进口/国产Imports / domestic	表层镀银Surface of silver		FINISH		
4	弹簧spring	碳素钢丝Carbon steel wire	进口/国产Imports / domestic	表层镀银Surface of silver		SEE NOTE		
5	弹片 Shrapnel	磷铜Phosphor copper	进口/国产Imports / domestic	表层镀银Surface of silver		Q'TY		
6	钩针 Crochet	黄铜 Brass	进口/国产Imports / domestic	表层镀银Surface of silver			THESE DRAWINGS AND SPECIFICATIONS ARE THE PROPERTY OF ACCURATE 3K-KAMING(LANG LUN) INC. AND SHALL NOT BE REPRODUCED, COPIED OR USED IN ANY MANNER WITHOUT THE PRIOR WRITTEN CONSENT OF ACCURATE 3K-KAMING(LANG LUN) INC.	
								东莞市朗纶电子制品有限公司 Dongguan langlun electronic products Co., Ltd
							TITLE: PUSH SWITCH / VERTICAL DR: Ricky 2015/03/23 CHKD: Ricky 2015/03/23 APPD:	PART NO.: 3K-8-001DA DWG NO.: 3K-8-001DA
							SCALE: 4:1 SHEET: 1/1 REV: A CUSTOMER DRAWING	