

Rating:  
 CQC 16(4)A 250V AC T85  
 UL cUL 16A 125V AC/16A 250V AC T125  
 VDE 16(4)A 250V AC T85

Circuit Diagram: 4P ON-OFF  
 Terminal Strength: ≥80N  
 Electrical life: ≥10000 cycles  
 Withstand Voltage: Withstand Voltage:1800VAC 1min  
 Terminals to Button:3000VAC 1min  
 Leakage Current: 1mA  
 Current resistance: ≤50mΩ(initial)  
 Insulation resistance: ≥100MΩ

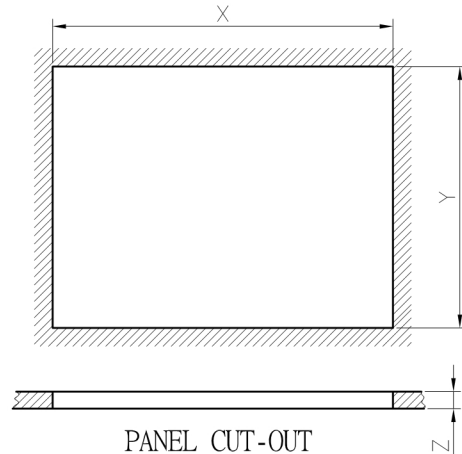
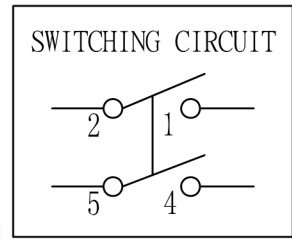
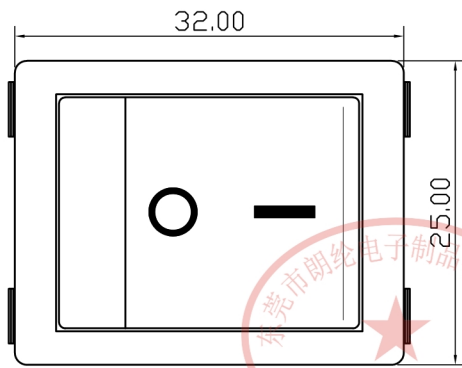

PANEL CUT-OUT		
Z	Y	X
0.70~1.25	21.90~22.10	29.9~30.1
1.25~2.00	21.90~22.10	30.1~30.3
2.00~3.00	21.90~22.10	30.3~30.5

东莞市朗纶电子制品有限公司  
 工程部

A4				普通公差:	<b>东莞市朗纶电子制品有限公司</b> <b>Dongguan langlun electronic products Co., Ltd</b>							
A3			COMMON TOLERANCE:	单位		mm	投影		品名	跷板开关	比例	1:1.5
A2			UP TO 5 ±0.20	UNIT			核 对		PRODUCT NAME		SCALE	
A1			ABOVE 5 TO 30 ±0.30	绘 图		朱文林	核 对	吴路方	型 号	3K606B-2010012CBB		
REV.	DATE	REVISION DESCRIPTION	ISSUE	ANGULAR ±5°	日期	2012.11.14	核 准	周培雷	图 号	3K606B-2010012CBB		