

Rating:
 CQC 6A 250V AC T85
 6A/125A 250VAC
 UL cUL 10A 125V AC/6A 250V AC
 VDE 6(4)A 250V AC T85/55
 KC 6(4)A 250V AC

Circuit Diagram: 3P ON-OFF

Terminal Strength: ≥80N

Electrical life: ≥10000 cycles

Withstand Voltage: Withstand Voltage:1800VAC 1min

Terminals to Button:3000VAC 1min

Leakage Current: 1mA

Current resistance: ≤50mΩ(initial)

Insulation resistance: ≥100MΩ

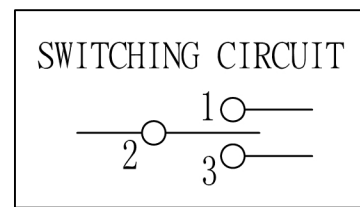

PANEL CUT-OUT		
Z	Y	X
0.70~1.25	20.00~20.10	2.10~2.20
1.25~2.00	20.10~20.20	2.10~2.20
2.00~3.00	20.20~20.30	2.10~2.20

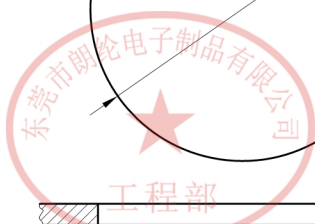
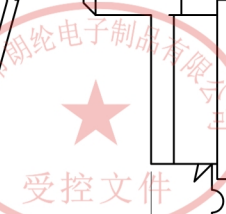
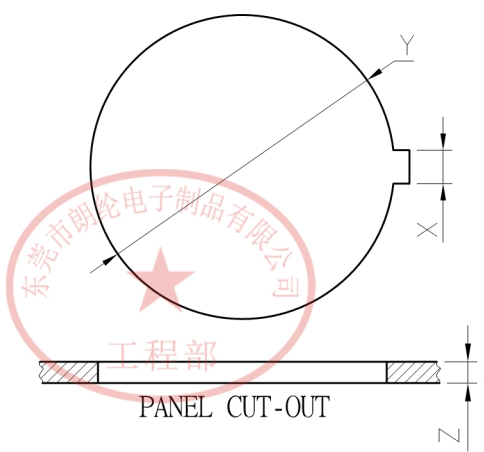
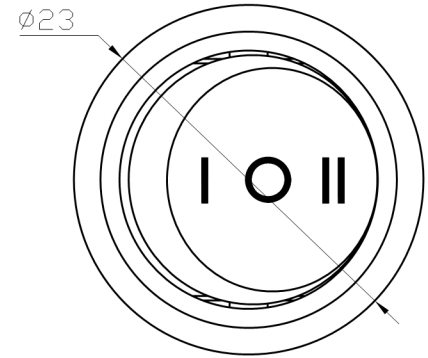
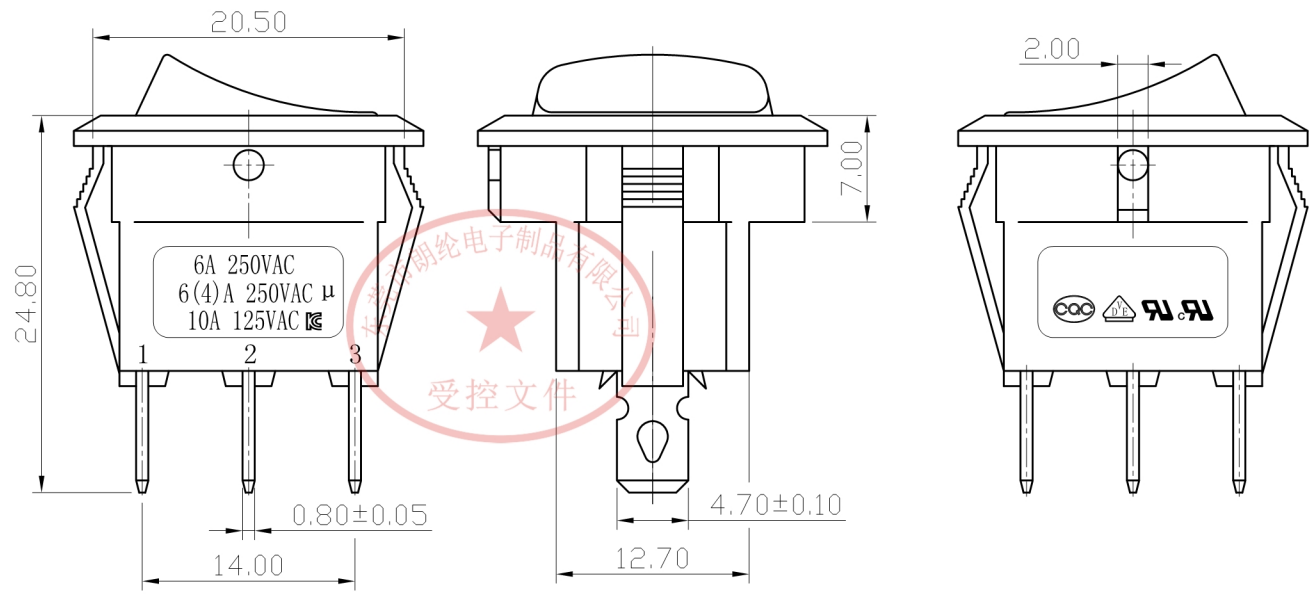

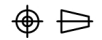
A4				普通公差:	 3K-KAMING	东莞市朗伦电子制品有限公司 Dongguan langlun electronic products Co., Ltd					
A3			COMMON TOLERANCE:	单位		投影		品名	跷板开关	比例	1.5:1
A2			UP TO 5	±0.20		mm		PROJECTED	PRODUCT NAME	SCALE	
A1			ABOVE 5 TO 30	±0.30		绘图	核对	型号	3K601C1-1030041BB		
			ABOVE 30	±0.50	DRAWN BY	CHECKED BY	图号	3K601C1-1030041BB			
REV.	DATE	REVISION DESCRIPTION	ISSUE	ANGULAR	日期	核准	DWG NO.				
				±5°	2012.11.14	周培雷					