

Rating:  
 CQC 6(4)A 250V AC T85  
 6A/125A 250VAC  
 UL cUL 10A 125V AC/6A 250V AC  
 VDE 6(4)A 250V AC T85  
 KC 6(4)A 250V AC T85

Circuit Diagram: 3P ON-ON

Terminal Strength:  $\geq 80N$

Electrical life:  $\geq 10000$  cycles

Withstand Voltage: Withstand Voltage: 1800VAC 1min

Terminals to Button: 3000VAC 1min

Leakage Current: 1mA

Current resistance:  $\leq 50m\Omega$  (initial)

Insulation resistance:  $\geq 100M\Omega$

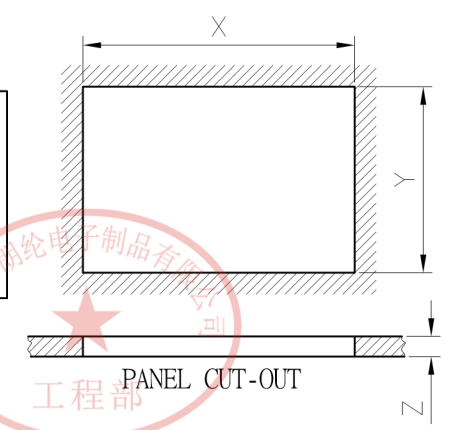
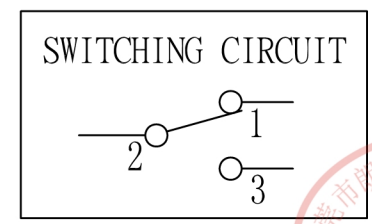
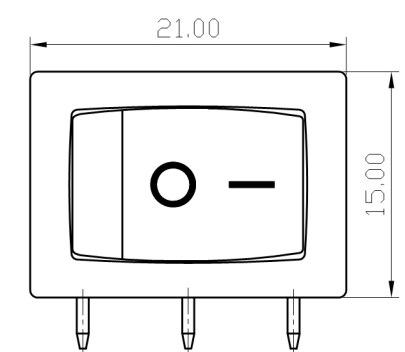

PANEL CUT-OUT		
Z	Y	X
0.70~1.25	12.90~13.10	18.90~19.10
1.25~2.00	12.90~13.10	19.10~19.20
2.00~3.00	12.90~13.10	19.30~19.40

A4				普通公差:	 <b>东莞市朗纶电子制品有限公司</b> <b>Dongguan langlun electronic products Co., Ltd</b>							
A3			COMMON TOLERANCE:									
A2			UP TO 5	$\pm 0.20$	单位	mm	投影		品名	跷板开关	比例	Free
A1			ABOVE 5 TO 30	$\pm 0.30$	绘图	朱文林	核对	吴路方	型号	3K601B-1020013BB		
			ABOVE 30	$\pm 0.50$	日期	2012.11.14	核准	周培雷	图号	3K601B-1020013BB		
REV.	DATE	REVISION DESCRIPTION	ISSUE	ANGULAR	$\pm 5^\circ$	日期	2012.11.14	核准	周培雷	图号	3K601B-1020013BB	