

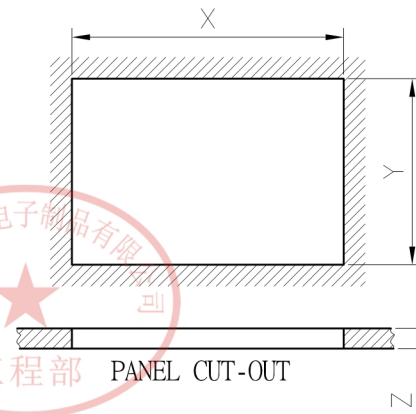

Rating:
 CQC 6(4)A 250V AC T85
 6A/125A 250VAC
 UL cUL 10A 125V AC/6A 250V AC
 VDE 6(4)A 250V AC T85
 KC 6(4)A 250V AC T85

Circuit Diagram: 3P ON-ON
 Terminal Strength: $\geq 80N$
 Electrical life: ≥ 10000 cycles
 Withstand Voltage: Withstand Voltage:1500VAC 1min
 Terminals to Button:3000VAC 1min
 Leakage Current: 1mA
 Current resistance: $\leq 50m\Omega$ (initial)
 Insulation resistance: $\geq 100M\Omega$

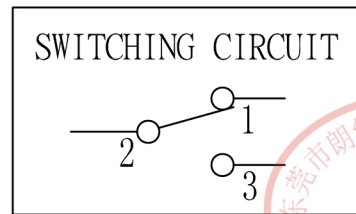
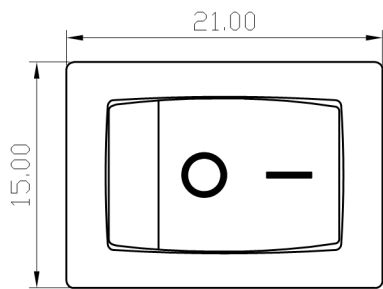

PANEL CUT-OUT		
Z	Y	X
0.70~1.25	12.90~13.10	18.9~19.1
1.25~2.00	12.90~13.10	19.1~19.2
2.00~3.00	12.90~13.10	19.3~19.4

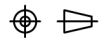
A4				普通公差:	 东莞市朗纶电子制品有限公司 Dongguan langlun electronic products Co., Ltd								
A3				COMMON TOLERANCE:		单位	mm	投影		品名	跷板开关	比例	2:1
A2				UP TO 5		± 0.20	UNIT	PROJECTED	核对	吴路方	型号	3K601B-1020012BB	
A1				ABOVE 5 TO 30		± 0.30	绘图	朱文林	CHECKED BY	周培雷	图号	3K601B-1020012BB	
REV.	DATE	REVISION DESCRIPTION	ISSUE	ANGULAR	$\pm 5^\circ$	日期	2012.11.14	核准	周培雷	DWG NO.	3K601B-1020012BB		