

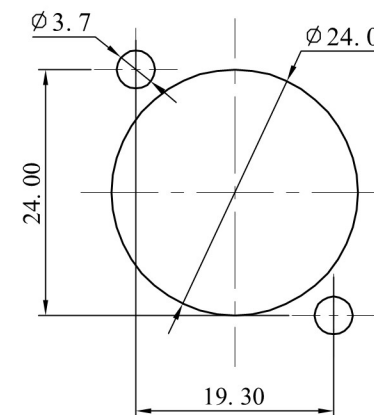

ALLOWANCE	
UNDER 3	± 0.1
3 TO 6	± 0.15
6 TO 15	± 0.2
15 TO 50	± 0.25
50 OVER	± 0.3

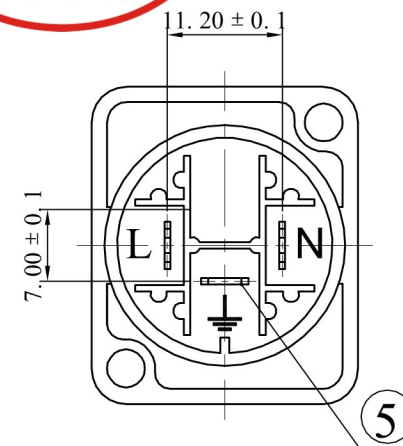
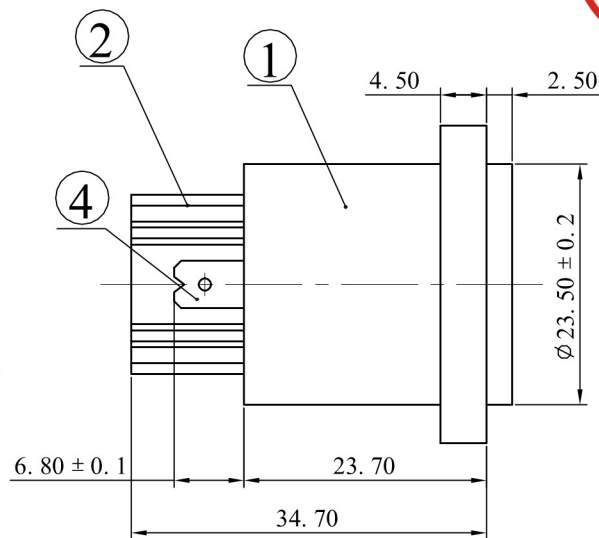
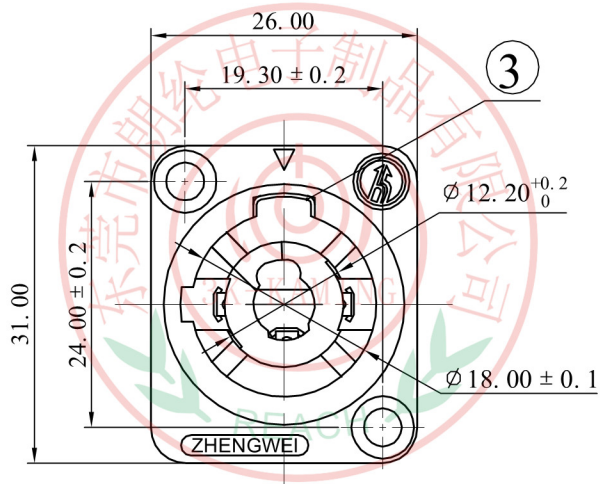

PANEL CUTOUT

Specifications:
 Rating :DC 250V,20A.
 Force:5~40N.
 Contact resistance:
 Less than30mΩ.
 Insulation resistance:
 Over 100MΩ on DC 500V measured.
 Voltage withstand :
 AC 500V,For 1 minute.



5	TERMINAL-2	BRONZE t=0.5	1	Ag PLATING
4	TERMINAL-1	BRONZE t=0.5	2	Ag PLATING
3	TERMINAL-E	STEEL t=0.3	1	
2	COVER	PA66	1	BLUE
1	HOUSE	PA66	1	BLUE
NO	PART NAME	MATERIAL	QTY	FINISHING

MODEL NO :SPE-27

ALLOWANCE:

DRAWN BY:

TYPE: SP SOCKET

UNIT: mm

CHECKED BY:

MATERIAL NO :50802701

SCALE:

APPROVED BY:

PROJECTION



东莞市朗纶电子制品有限公司
 Dongguan langlun electronic products Co., Ltd